

OPERATOR'S MANUAL

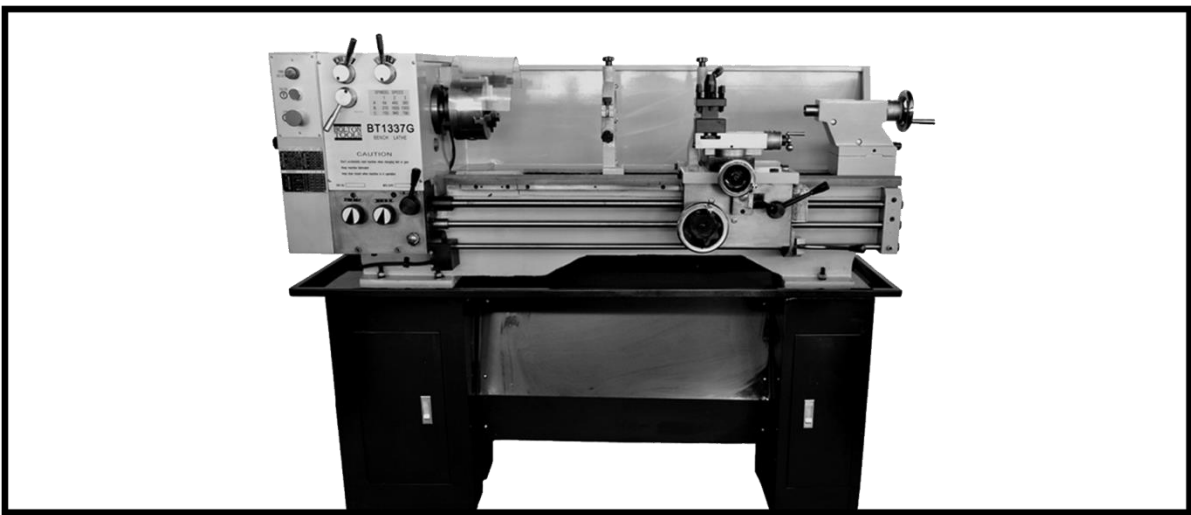

**BENCH LATHE
MODEL: BT1337G**

Many thanks for purchasing our BT1337G - Bench Lathe. Before operating, make sure you study the manual to have a better understanding of the operating procedures. This manual will guide you through assembly, will cover general maintenance, and review safety considerations.

Table of Contents

1. SPECIFICATION	4
2. STANDARD ACCESSORY	4
3. OPTIONAL ACCESSORY	4
4. ELECTRICAL SYSTEM	4
4.1 ELECTRIC PRINCIPLE CHART	5
4.2 WIRE CHART	6
4.3 DESCRIPTION	8
5. INSTALLATION	8
5.1 FOUNDATION	8
5.2 LIFTING	9
5.3 CLEANING	9
6. LEVELING	10
7. LUBRICATING CHART	11
8. OPERATING INSTRUMENT	12
8.1 CAUTION	12
8.2 HEADSTOCK	13
8.3 SPINDLE SPEED	13
8.4 MAIN SPINDLE ROTATION	14
8.5 GEAR BOX	14
8.6 CARRIAGE	16
8.6.1 POWER FEED	16
8.6.2 THREADING DIAL	17
8.7 FOUR POSITION TOOL POST	17
8.8 COMPOUND SLIDE	18
8.9 TAILSTOCK	18
9. PROTECTION INSTRUMENTS	18
10. CHECK PROBLEMS AND REPAIRING	19
10.1 Turn on the electrical and the spindle doesn't rotate	19
10.2 The motor is too hot or not powerful	19
10.3 The temperature of spindle bearing is too high	19
10.4 Short of motive force when spindle is rotating	19
10.5 Making small taper when external turning	19
10.6 During proceeding, the surface of the work piece is very rough	19
10.7 Failing to make contact with electrical surface	19
11. MAINTENANCE	20
11.1 Daily maintenance	20
11.2 Weekly maintenance	20
11.3 Monthly maintenance	20
11.4 Yearly maintenance	20

1. SPECIFICATION

(1) Swing over bed	12.99"
(2) Swing over gap	19.09"
(3) Swing over saddle	8.46"
(4) Distance between centers	37"
(5) Length of bed	58"
(6) Width of bed	7.17"
(7) Hole through spindle	1.5"
(8) Tailstock barrel travel	3.94"
(9) Cross slide travel	5.91"
(10) Tool slide travel	3.54"
(11) Saddle travel	33.46"
(12) Taper of spindle hole	M.T.5
(13) Taper of tailstock barrel	M.T.3
(14) Range of spindle speed	9steps 64-1500RPM
(15) Diameter of lead screw	0.87"
(16) Diameter of feed rod	0.75"
(17) Thread of lead screw	8T.P.I.(inch)3mm(metric)
(18) Thread can be cut inch	14kinds 7.5-48T.P.I. metric 11 kinds 0.5-3mm
(19) Motor power	1.5HP
(20) Net weight with/without stand	858lb/726lb
(21) Packing size without stand	70.08" ×29.13" ×29.53"
(22) Packing size of stand	28.35" ×11.81" ×27.56"
(23) Noise	<83dB

2. STANDARD ACCESSORY

- (1) Tool post wrench (2) Double end wrench 14-17 (3) Allen wrench 3mm, 4mm, 5mm, 6mm, 8mm (4) Screw driver 6×100 (5) Center M.T.3 (6) Center sleeve M.T.5/M.T.3 (7) Oil gun (8) Follow rest (9) Steady rest (10) Change gears (11) Three jaw chuck (12) Tool box

3. OPTIONAL ACCESSORY

- (1) Machine stand (2) Four jaw chuck (3) Face plate (4) Live center

4. ELECTRICAL SYSTEM

Standard lathe is wired for 220V, single phase 50 cycles; other connections can be made as customers' requirements.

The electrical system in the lathe has been installed and adjusted in the factory. Please don't open the electrical box. Before operating, wire the proper power source to the lathe and connect the ground wire. Turn on the power and check the running direction of the spindle. If wrong, turn off the motor and cut the power source, then change the wires as the wiring chart.

Voltage/Phase	Single Phase	Three Phase
110V	30A	
220V	15A	7.5A
380V		5A

4.1 ELECTRIC PRINCIPLE CHART THREE PHASES

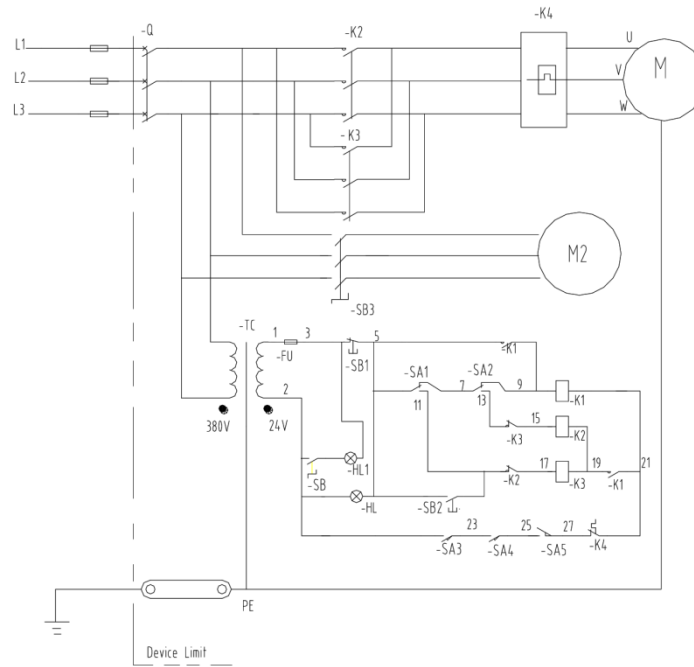

SINGLE PHASE

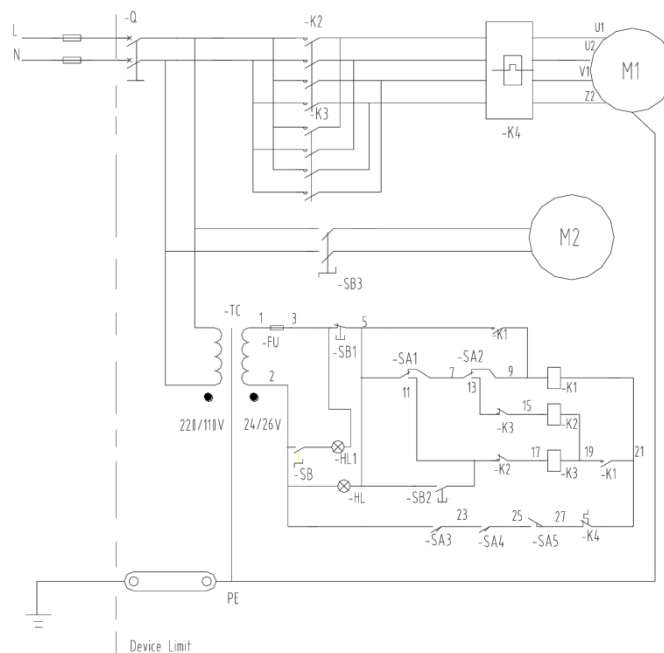

4.2 WIRE CHART THREE PHASE

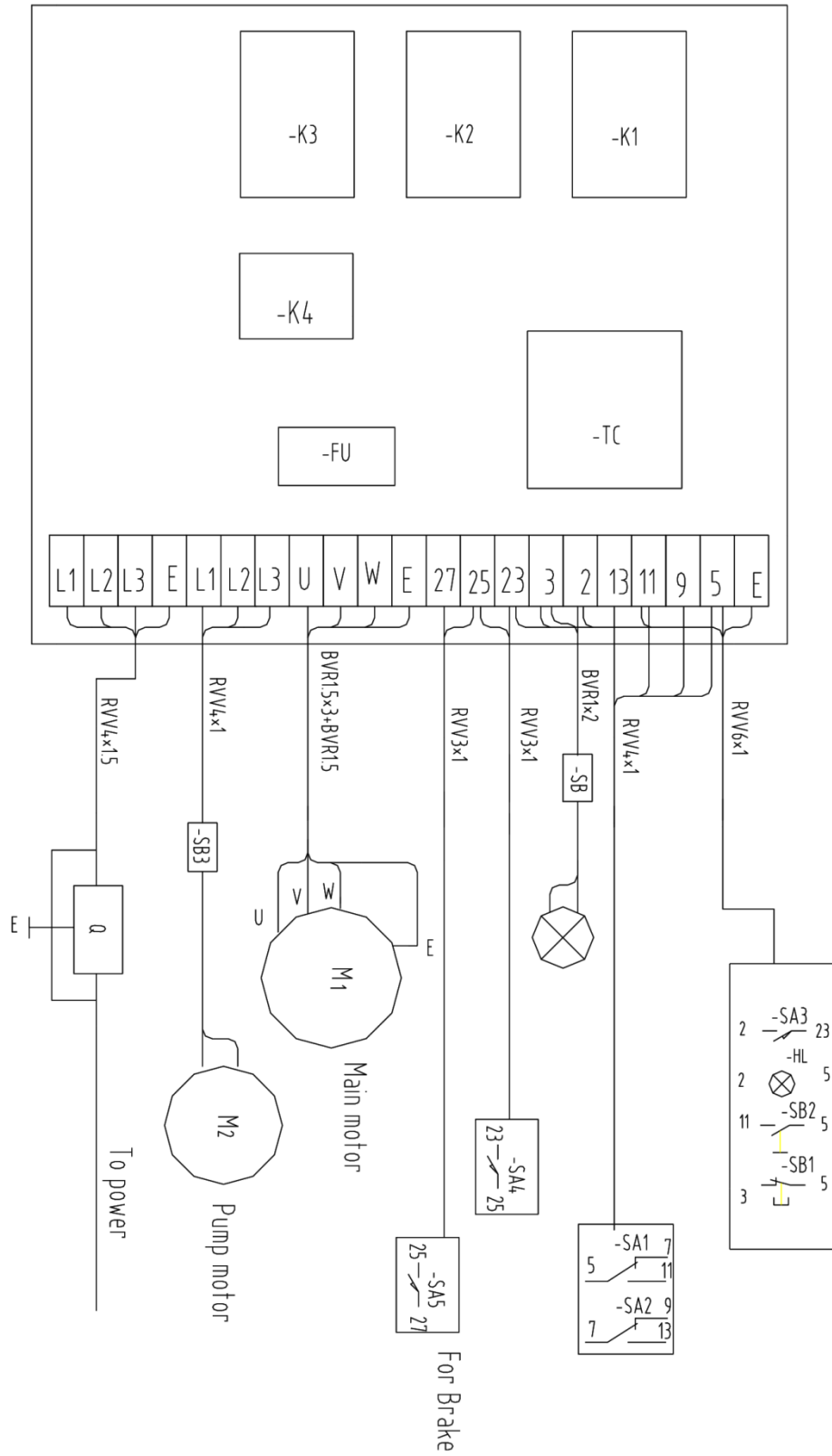

SINGLE PHASE

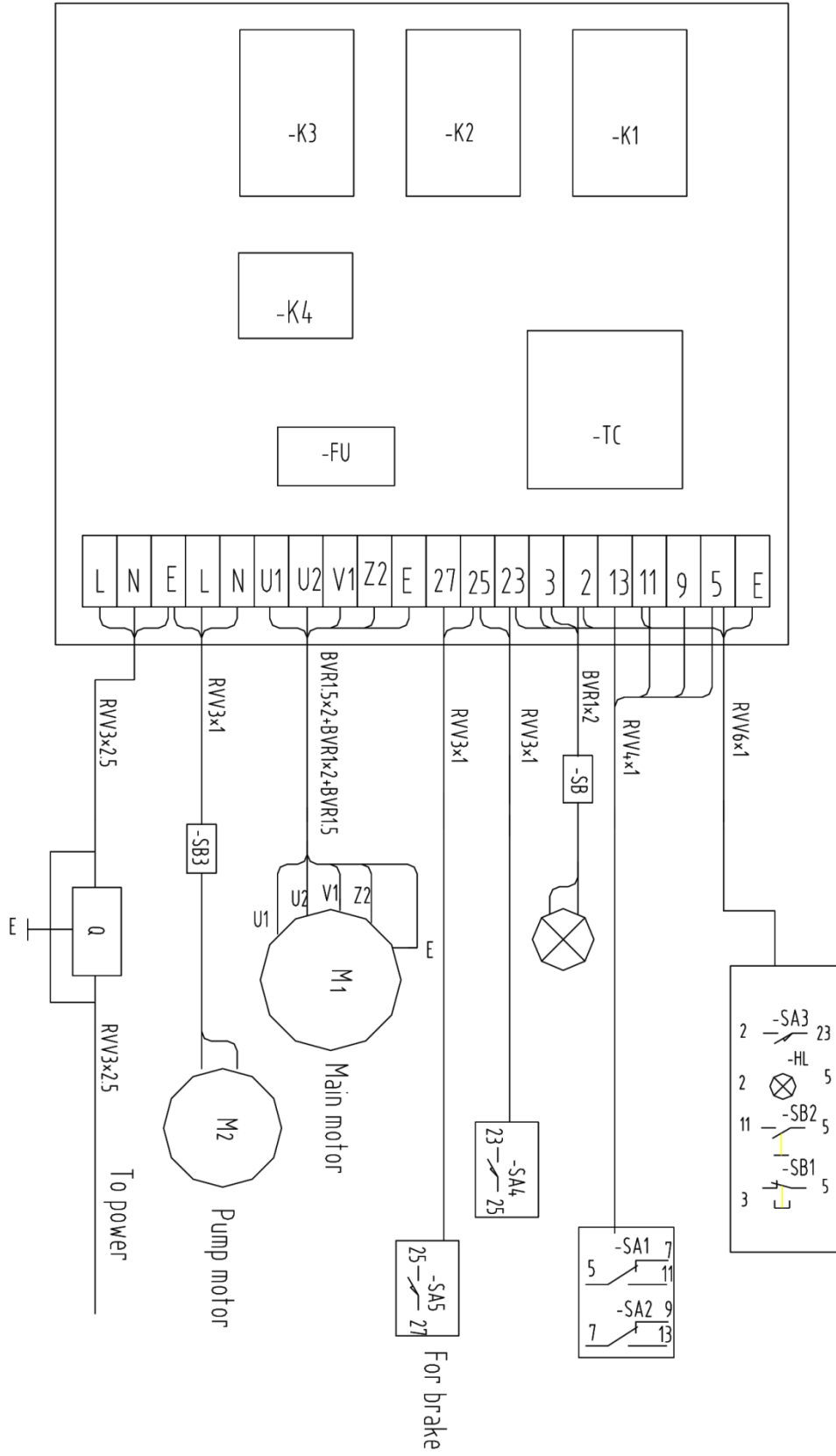

4.3 DESCRIPTION

SIGN	NAME	SIGE	NAME
M	Motor	SB2	Jog switch
TC	Transformer	SA3	Pulley cover limiting switch
HL	Indicator light	SA4	Chuck cover limiting switch
HL1	Work light	SA5	Brake switch
SB1	Stop switch	K4	Heat relay

5. INSTALLATION?

CAUTION: THE MACHINE MUST BE SECURED, FIRM AND STABLE. DON'T TURN DOWN OR MAKE ANY SUDDEN MOVEMENT WITHOUT INSPECTION BECAUSE OF SHAKING, WIND POWER, LASHING OR OTHER EXPECTED OUTER POWER OR INTERNAL MOVEMENT FORCE (SUCH AS FORCE, MOTOR POWER FORCE, ETC.)

5.1 FOUNDATION

The base of the machines foundation must be solid and heavy enough to support the weight, without noticeable defects. The floor must be fairly leveled. Concrete floor is the best foundation. It provides a rigid base and minimizes vibration from adjacent machines. The floor strength must be tested. The testing method: place a level on the floor and put the machine on installation position, if the bubble shows appreciable deflection, the floor must be reinforced.

When determining the position of installation, leave a space on the left, right, front and back of the machine in accordance with its overall dimension and installation dimension of the machine so that the operating and repairing is convenient.

If you use our stand (optional accessory), please, make a mark and drill eight holes in the eight fitting hole position of the base according to the fitting dimension of the stand. Cover eight foundation bolts in the base (note position precision when determine the fitting hole position). Put the stand on the base, connecting to the eight foundation bolts, then place two adjustable iron spacers in each, down face of front, back of two stands (in order to increase the touched space, please stagger the position of front and back adjustable iron spacer). Fix the connecting block of left, right of stand, fit the stand on the base. At last, lift the lathe on the stand and connect and fix the lathe to the stand by using nuts and bolts.

When fitting the lathe directly on the base, firstly, in accordance with fitting dimension, mark and drill holes in the base of the six fitting hole position of the lathe. Cover six foundation bolts in the base. Place two adjustable iron spacers on the base in the front and back of the spindle box position and place one adjustable iron spacer on the base in the cross direction of the tailstock position, then lift the lathe on the adjustable iron spacers.

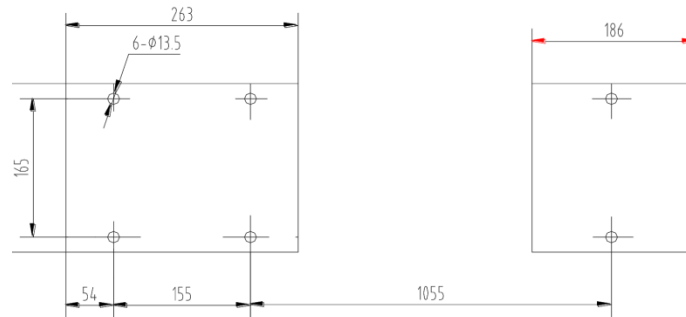

Fitting dimension without stand

5.2 LIFTING

Lifting the lathe as the following figure shows.



Put the mats in which the lifting tools connect before lifting the lathe, to avoid damaging the machine's surface.

The lathe net weight 330kg (728lbs), stand weight 60kg (132lbs). You must keep the machine in balance to avoid tilting.

The carriage, tailstock and other sliding parts of the lathe are locked before leaving factory. Don't loosen these when lifting and should inspect to confirm whether they are locked or not in order to prevent the parts from sliding. Carefully install the machine on the base or stand with bolts and nuts.

5.3 CLEANING

Prior to shipment, all machines and their finished surfaces are coated with antirust oil to protect and prevent rusting. Before moving the carriage or tailstock, use multi-purpose cleanser to remove the rust preventive coating. Use a brush and the cleanser to clean the ways of any residue or rust preventive coating. Such care in the cleaning will ensure the removal of any foreign particles and prevent the way from rusting or damaging. Lubricate the ways after you are done cleaning.

6. LEVELING

The lathe should be kept perfectly leveled at all times.

Leveling procedure:

A. Longitudinal leveling

After the bedways are dry, remove the base screw. Place a 6" precision machinist level over working table in a longitudinal direction (bed length direction). Move the working table at the headstock end along bed length direction. Level and adjust the adjustable iron spacer, to obtain a good reading. Then move the working table to the tailstock, adjust the screw of the adjustable iron spacer until the level obtains the same reading as on the headstock end.



on the headstock end



on the tailstock

B. Cross leveling

Put the level on the working table along cross direction 13 (bed width direction). Move the working table to the headstock end along bed length direction. Take a reading, then move the working table to the tailstock end. The reading at this end must be exactly the same as the other end. If the reading is not same, adjust the screw of the adjustable iron spacer to get the same reading.



On the headstock end

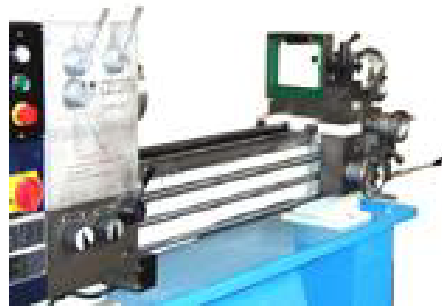

on the tailstock end

The adjustments at one end will affect the reading of the other, so that leveling procedure should repeat many times, making necessary adjustments using the staff ruler and the iron spacer. After the adjustments are made, turn down the foundation bolt slightly, until they rest under slight tension. The tension should be such that it does not change the Level reading. Recheck level after fixing the bolt; if necessary, make minor adjustment.

After the machine has been put to use for a period of time, check level to observe if the original adjustments exist. Make adjustments as mentioned above if necessary. (Make an erasable mark at one end of the Level to keep the same direction for every reading).

CAUTION: THE LOW PRECISION SPIRIT LEVEL MUST NOT BE USED. SCHEDULE OR PERIODICLY LEVEL CHECK AS A PART OF YOUR MAINTENANCE SCHEDULE.

7. LUBRICATION CHART

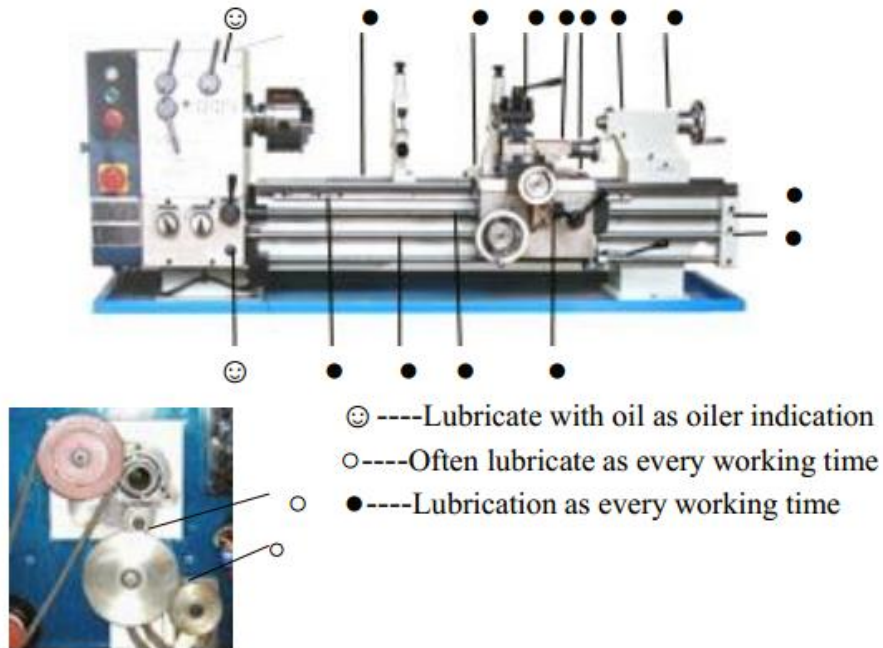

CAUTION: LUBRICATION IS AN IMPORTANT FACTOR OF MACHINE MAINTENANCE. THE QUANTITY OF LUBRICATION OIL MUST BE MODERATE. IF LUBRICATION IS INSUFFICIENT, IT WILL AFFECT THE PRECISION OF THE MACHINE, AND DAMAGE THE MACHING. IF LUBRICATION IS TOO MUCH; IT WILL BE WASTED AND MAKE THE WORKING AREA MESSY AND UNSTABLE. IT IS SUITABLE FOR THE QUANTITY OF THE LUBRICATION OIL NOT TO OVERFLOW OR COME OFF.

8. OPERATION INSTRUCTION

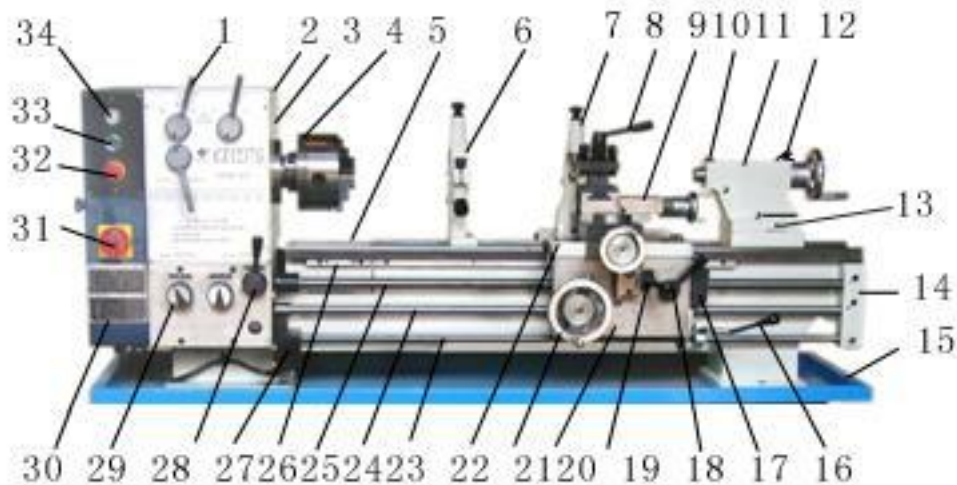

5. Gap Slide 10. Sleeve clamping lever 11. Tailstock 12. Tailstock clamping lever
13. Adjusting screw 14. Three rod support seat 15. Chip pan 16. Control lever
17. Threading dial 18. Half nut lever 19. Cross/longitudinal feed lever 20. Apron
21. Longitudinal feed handwheel 22. Carriage 23. Control rod 24. Feed rod
25. Lead screw 26. Rack 27. Limiting switch box 28. Feed rod and leadscrew exchange
lever 29. Change gear handle 30. Pulley cover 31. Power switch 32. Emergency switch
33. Start switch 34. Indication light

8.1 CAUTION

A: DO NOT OPERATE THE LATHE BEFORE YOU THOROUGHLY UNDERSTAND ALL THE CONTROLS AND FUNCTIONS. BEFORE CUTTING ANY WORK PIECE, RUN A TRIAL IN ORDER TO FAMILIARIZE YOURSELF WITH THE FUNCTIONS.

B: BEFORE OPERATING, CHECK OIL LEVELS AND LUBRICATION OF ALL SLIDING AND ROTATING PARTS. IF LUBRICATION IS NOT ENOUGH, SEE LUBRICATION CHART AND LUBRICATE ACCORDINGLY.

C: THE LATHE IS NOT EQUIPT WITH LIGHTS. YOU SHOULD PROVIDE ENOUGH LIGHT AND AVOID WORKING IN THE DARK TO PREVENT ANY DANGEROUS EVENT FROM HAPPENING.

D: ALWAYS KEEP YOUR WORKPIECE CLAMPED FIRMLY TO PREVENT IT FROM FLYING OFF. THE OUTSANDING PART OF THE PIECE SHOULD NOT BE MORE THAN 80MM (3"). THE LENGTH AND DIAMETER FOR THE OUTSTANDING PART SHOULD BE, NOT MORE THAN 4".

E: WHEN ACCIDENTS HAPPEN DURING OPERATION, PLEASE CUT OFF POWER AT ONCE BY ENGAGING EMERGENCY STOP BUTTON.

G: CUTTING AMOUNT SELECTION: WHEN CHOOSING THE CUT AMOUNT, YOU MUST CONSIDER THE LATHE, TOOL OR WORKPIECE RIGID. DON'T OVERLOAD A CUT. PREVENT THE DANGER FROM WORKPIECE BREAKING. IN GENERAL, CUTTING METAL MATERIAL AS THE FOLLOWING FIGURE (SLIGHTLY ENLARGE THE CUT AMOUNT WHEN CUTTING WOOD, PLASTIC, NONMETAL MATERIAL, ETC.)

Work piece diameter	Cut speed (RPM)	Cut depth (MM)	Feed amount (MM/Turn)
$\geq \phi 150$	<160	<0.5	<0.1
$\geq \phi 100-150$	<200	<0.5	<0.1
$\geq \phi 50-100$	<400	<1	<0.15
$\geq \phi 30-50$	<1000	<1.5	<0.15
< $\phi 30$	<1300	<1	<0.1

NOTE: WHEN THE RATE OF THE OUTSTANDING AND DIAMETER OF WORK PIECE IS OVER 4", THE DEPTH OF CUT AND FEED AMOUNT SHOULD BE LESS.

H: WHEN YOU ARE DONE WORKING, TURN OFF THE POWER AND CLEAN THE LATHE.

I: WHILE MAKING ANY ADJUSTMENTS, REPAIRS OR MAINTENANCE TO THE MACHINE, CUT THE POWER OFF FOR YOUR SAFETY.

8.2 HEADSTOCK

The main spindle is driven by gears; it has three groups of sliding gears which position can be changed by operating lever (1). The machine is equipped with a belt from the motor to the spindle pulley. The tension of the belt has been adjusted properly in factory. It is advised to check the tension before starting the machine. The belt should depress about 1/2 inch by normal finger pressure, tightening the belt will damage the bearings. A loose belt will wear easy and slide. When necessary, adjust the belt tension and adjust the bolt under the motor bracket to leave the motor in a proper position and the belt with proper tension. The oil in the headstock should be changed regularly. First, change the oil after you continue using for 15 days. Second, change it after 45 days and then change it every six months or once a year. It has a hole under the headstock and has a screw cover on it. Remove the screw; the oil in the headstock will flow out. After it is drained, you should clean the inside of the headstock using gas oil or kerosene. Then pour the clean lubricating oil in the headstock until the level reaches the red line in the oil gauge.

CAUTION: AT ALL TIMES, THE OIL IN OIL RESERVOIRS MUST BE MAINTAINED. IF NOT, PLEASE ADD OIL ACCORDING TO OIL GAUGE.

8.3 SPINDLE SPEED

Main spindle can shift 9 different speeds by changing the lever according to **brand showing**. Proceed as follows:

- 1) Move the control lever to middle position, and turn the motor off;
- 2) According to speed chart, move the two levers (A), (B), point arrowhead in the direction of the line A, B, C, or 1, 2, 3, which shows on the name plate. When moving the lever you will see it is difficult. You may move the chuck by hand, to engage the gear.

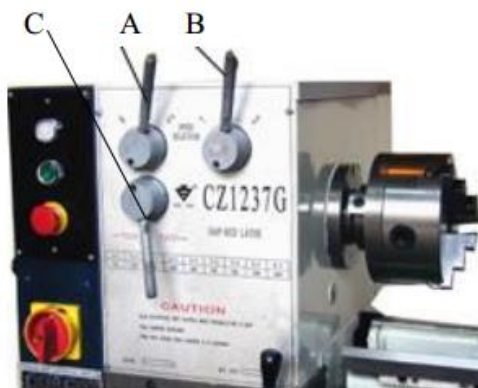

	1	2	3
A	64	460	380
B	210	1500	1300
C	130	940	790

C---changing direction lever

CAUTION: DON'T CHANGE SPEED WHEN THE SPINDLE IS RUNNING.

8.4 MAIN SPINDLE ROTATION

Starting, stopping, forward and reverse of spindle can be made merely by the control lever. When using the control rod, pull the lever in the headstock direction, then pull up and down.



Control lever on the top position



Control lever in the middle position



Control lever in the bottom position

Moving the control lever down the spindle will be forward rotation. Control lever up and the spindle will be in reverse rotation. Control lever in the middle will make it stop. If the motor is one phase and you need to change the direction of the spindle, please move the control lever from one side to the middle, till the motor stops. Then move up or down. If you move the control lever from one side directly to another side, the direction of the spindle won't change.

8.5 GEAR BOX

Quick-change gear system, designs the rate of the spindle to lead screw and feed rod when it is used to cut thread or external turning and facing. Quick-change gear box is controlled by two handles. Handle (1) exits A, B, C, three positions. Handle (2) has 1, 2, 3, three positions.

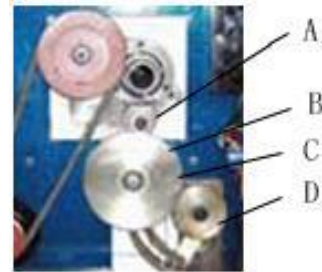

Handle (3) has three positions which is left middle and right. Handle to the left is used for external turning, internal turning and facing. The handle to the middle is parking. Handle to the right engages leadscrew for cutting thread. This machine can be used to use to cut metric and standard threads, when handles (1) and (2) are positioned in the corresponding position. Please change gears A, B, C, or D. when necessary.





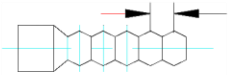
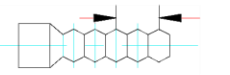
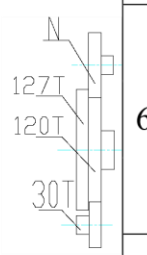
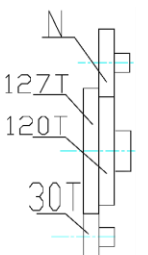
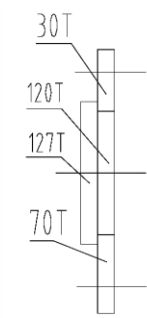

- | | | | |
|---|-------------------------|---------|---------|
| 1) Gear changing handle | 2) Gear changing handle | A) Gear | B) Gear |
| 3) Feed rod and leadscrew changing handle | | C) Gear | D) Gear |

Half nut must be kept engaged to leadscrew at all times, when the thread is being cut. Every time you are finished cutting, move tool back and reverse the motor. Then take the tool to the start-cutting position and begin the next process. Continue the process until you have completed the threads.

CAUTION: DO NOT CHANGE THE HANDLE (1) (2) (3) WHEN THE MACHINE IS RUNNING

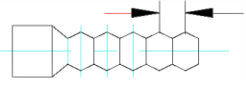
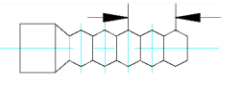
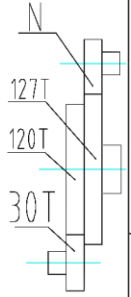
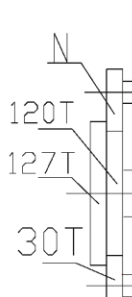
 MM					 /INCH					
	N	I	II	III		N	I	II	III	
 127T 120T 30T	A	---	2.5	1.25	 127T 120T 30T	60	B	48	12	24
	B	0.5	2	1		C	32	8	16	
	C	0.75	3	1.5		64	A	36	9	18
	64	C	0.8	---		---	B	45	---	22-1/2
	70	C	---	3.5		1.75	C	30	7-1/2	15
FEEDING						I	II	III		
 30T 120T 127T 70T	 MM/O				A	0.063	0.253	0.126		
					B	0.051	0.202	0.101		
					C	0.076	0.303	0.152		
	 INCH/O				A	0.0025	0.010	0.005		
					B	0.002	0.008	0.004		
					C	0.003	0.012	0.006		

B. Table for inch lead screw.

										
MM					/INCH					
	N	I	II	III		N	I	II	III	
	A	---	2.5	1.25		60	B	48	12	24
	B	0.5	2	1		C	32	8	16	
	C	0.75	3	1.5		64	A	36	9	18
	64	C	0.8	---		---	B	45	---	22-1/2
	70	C	---	3.5		1.75	C	30	7-1/2	15
FEEDING						I	II	III		
					A	0.063	0.253	0.126		
					B	0.051	0.202	0.101		
					C	0.076	0.303	0.152		
					A	0.0025	0.010	0.005		
					B	0.002	0.008	0.004		
					C	0.003	0.012	0.006		

8.6 CARRIAGE

The function of the carriage is firmly to support the tool post and carry it, by moving in longitudinal and cross direction.

8.6.1 Power feed

For external turning and facing, turn lever (28) on the gear box to “left” to make the feed rod rotate.

To power feed in longitudinal direction, up engage the cross/longitudinal feed lever (A). To power feed in a cross direction, down engage the cross/longitudinal feed lever (A) in the

middle and engage the half nut. If done correctly, you will achieve the lead screw rotating and the carriage to move left and right.

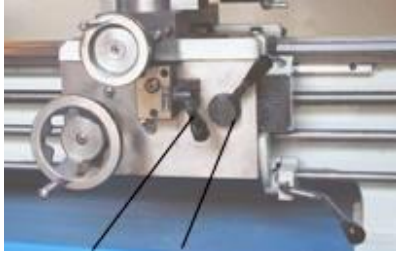

While the cross/longitudinal feed lever is in the feed position, the half nut lever (B) can be engaged, safety interlock mechanism will prevent simultaneous engagement of (A) and (B). For threading, put the lever (28) A B on the gear box to the right. Then move the cross/longitudinal feed lever (A) to the middle and engage the half nut.

CAUTION: DO NOT FORCE THE HALF NUT LEVER WHILE ENGAGING WITH THE LEAD SCREW.

When you power feed the spindle is what decides which way to engage the carriage. When the spindle rotates clockwise, the carriage moves left. Conversely to the right.

8.6.2 THREADING DIAL

When the pitch proportion of the lead screw and work piece thread is not integer times and need to open the half nut while cutting, it is necessary to use the threading dial to control tools and prevent the mixed screw. The threading dial is located on the right or left side of the apron. It performs the important function of indicating the proper time to engage the half nut lever, so that the tool will enter the same groove of the thread on each successive cut. The dial is marked with lines numbered 1.2.3.4. and in between are lines with no numbers. These are half lines and are called unnumbered lines. The dial engaged with the leadscrew, causes rotation of the dial, and a single line is marked on the housing of the threading dial (fixed line).

The instruction plate riveted on the threading dial shows the selection and sequence of matching the revolving lines with the fixed line.

For thread cutting, engage the half nut with the appropriate numbers shown on the scale column of the threading dial plate. 1-4 on the scale means the half nut can be engaged on any of the numbered lines 1-2-3-4. For each successive cut, only numbered lines must be used. 1-3/2-4 on the scale means the half nut can be engaged on 1 and 3 or 2 and 4. For successive cuts, when you engage the half nut on the numbered line "1" or "3" you engage the half nut on the numbered line "2" for the first cut. After that, the half nut will be engaged on the numbered line "2" or "4". 1-8 means the half nut just be engaged on any line, numbered or unnumbered.

If the half nut engages with the lead screw all the time while cutting the thread, you don't need to use the threading dial. After cutting, back the tool and reverse the motor, then move the tool to the last start cutting position and make the next cut.

8.7 FOUR POSITION TOOL POST

The main function of tool post is to fix tool, if necessary. Tool post may fix more than one tool (at most 4). Tool thickness must be less than tool groove. When installing a tool again, you should confirm the tool head direction to the work piece revolving center line. Use an iron spacer to adjust. After adjusting correctly, please fix the tool. If turning the tool post, turn the tool post locking handle counter clockwise to loosen the locking handle and turn the tool post to the position you need. Then turn the tool post lock handle clockwise to lock tool post.

8.8 COMPOUND SLIDE

Using the compound slide can cut tapers. When cutting tapers, please loose the screw on the saddle, around the compound slide. Face the graduated line towards the graduating number on the saddle. Then fix the screw, around the driving handwheel. The tool post moves the tool, and now there is an angle between the traveling line and turning line of spindle. Now you can turn a taper.

8.9 TAILSTOCK

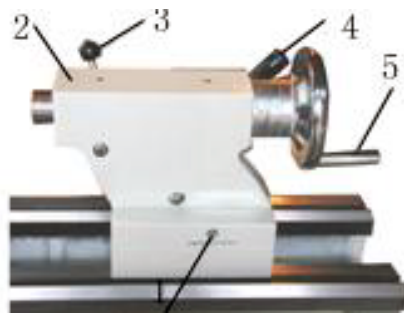

The tailstock slides along the bedways freely and can be locked in any position by the clamp lever (4). There is an end pin to stop the tailstock sliding down. Rotating the tailstock handwheel (5) can slide the quill. The quill can be locked by the quill lock lever (3). Before leaving the factory, it will be sure that it is the same line between the tailstock center and spindle center. For cutting small tapers, you must loosen the clamp lever (4) in advance and adjust the set over screw (1). It makes the deviation between spindle center and tailstock center. After make sure you lock the clamp lever and start machining.

Once you're finished, set the tailstock back in the same way when doing the external turning by using the tailstock center and get a taper work piece. As mentioned above, adjust the two set over screws (1) and back up the tailstock correctly to eliminate the taper.

When correcting, use a precise cylinder to connect the two centers of spindle and tailstock. Then place a meter on the worktable and make it's center head contact to the cylinder side center line. When you move the worktable to the end of headstock, take a reading from the meter, then move the meter to the tailstock end, otherwise use the same way as mentioned above to make adjustments to get the same reading at both ends.

9. PROTECTION GUARDS

The lathe can be equipped with several safety protection guards. Protect your body not to be hurt and make it a safe work environment. These guards include; chuck cover with micro switch system; tool post cover with micro switch system; pulley cover with micro switch system. Etc. For example, if the chuck cover is being turned over, the machine stop running immediately. The machine can run only when every cover is put down and every micro switch is turned on.

CAUTION: BE CAREFUL TO USE THE SAFETY PROTECTION GUARDS. IF NOT WORKING, REPAIR THEM IMMEDIATELY

10. CHECK PROBLEMS AND REPAIRING

CAUTION: BEFORE CHECKING, PLEASE TURN OFF THE ELECTRICAL POWER.

- 10.1 Turn on the electrical and the spindle doesn't rotate.
- A) The voltage is not right and the main switch turned off. Please adjust the input voltage and turn on the main switch.
 - B) The fuse in the electric box is brown. Please check and make repairs.
 - C) Electric connector is loosening. Please check and make repairs.
- 10.2 The motor is too hot or not powerful.
- A) Overloading or working time too long. Please reduce it.
 - B) The voltage is too low. Adjust to correct voltage.
 - C) Poor quality of motor. Please change a new one.
 - D) The fuse or wire contacting is not good (will easily make the motor short circuit). Please turn off the electrical and replace with a new fuse.
 - E) The belt is too tight. Please loosen it and adjust it to correct.
- 10.3 The temperature of spindle bearing is too high.
- A) Having not enough lubrication oil. Please fill the oil according to oil gauge.
 - B) The bearing assembly is too tight. Normally, rotate the spindle by hand easily, otherwise, adjust the spindle back nut.
 - C) High speed turning for long time. Slightly reduce the cutting amount.
- 10.4 Short of motive force when the spindle is rotating.
- A) The belt is too loose or worn and tired. Please adjust the belt tension to correct or change.
 - B) The motor is burnt. Please replace with a new one.
 - C) The fuse has blown. Please replace with a new one.
- 10.5 Making small taper when external turning
- A) It is not on the same line between the spindle center and tailstock center. Please adjust the tailstock according to operation manual instructions.
 - B) The moving line of carriage does not parallel to the spindle center. Please loosen the lock screw of headstock and adjust the spindle center to required position and lock.
- 10.6 During proceeding, the surface of the work piece is very rough.
- A) The space of the spindle bearing is too big. Adjust it to correct or replace with a new one.
 - B) The space between the saddle and the gib is too big. Adjust them to correct.
 - C) The tool is not sharp. Please sharpen it.
 - D) The work piece does not lock tightly. Please lock it tightly.
 - E) The precision of spindle bearing is too bad to wear. Please replace with a new one.
- 10.7 Failing to make contact with electrical surface.
- A) The cable is damaged or worn. Change a new cable.
 - B) Link to ground not making contact. Fix it and make sure there is contact to ground.
 - C) The cable terminal is coming loose or not working. Tighten it or repair if needed.

11. MAINTENANCE

Please always keep the machine in good condition. It is advisable to say maintenance is better than repair.

11.1 Daily maintenance

- A) Before using every day, please pour the oil and lubricate all the moving parts.
- B) If the spindle temperature is too high or machine too noisy, please stop the machine and check it in order to keep its precision.
- C) When your lathe is in trouble, please stop to repair it. If you don't do it well, please ask for the help from the local supplier or repairman.
- D) It is not recommended to overload the lathe.
- E) Before leaving the workshop, please clean the working area, turn off the power, be careful to clean the iron chippings and shavings and dust. Make sure you lubricate the machine and fill the oil reservoir.

11.2 Weekly maintenance

- A) Clean and protect the lead screw and feed rod.
- B) Look at all the sliding and turning surfaces and lubricate. Fill reservoir if needed.

11.3 Monthly maintenance

- A) Adjust the gib space of the saddle.
- B) Lubricate the worm gear, half nut and bearing in order to prevent wearing.

11.4 Yearly maintenance

- A) Level the machine in order to keep the accuracy and precision.
- B) Check the cable, terminal, switch and other electrical in order to prevent loosening, please replace if necessary.
- C) Check the accuracy of machine with the accuracy checking chart. Adjust if needed.

THE ABOVE ILLUSTRATIONS AND SPECIFICATIONS ARE SUBJECT TO ALTERATION WITHOUT NOTICE.

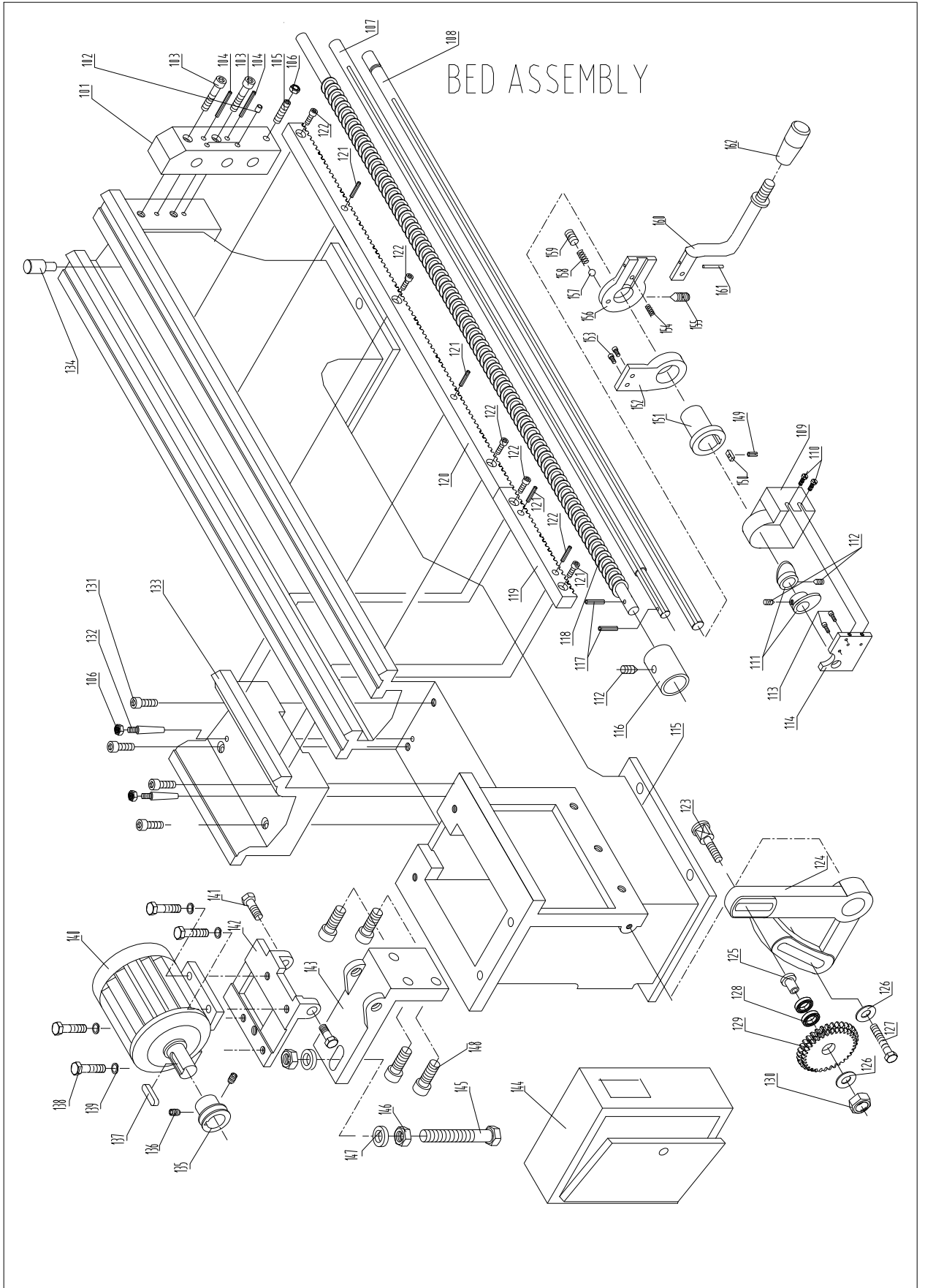

Index No.	Part No.	Description	QTY.
101	CM1224C-01-011	Fixing block	1
102	JB/T7940.4	Oil cup 6	2
103	GB/T70	Screw M8×25	2
104	GB/T879	Spring pin 5×25	2
105	GB/T77	Screw M8×20	1
106	GB/T41	Nut M8	1
107	CM1237CHG-01-009	Feeding rod	1
108	CM1237CHG-01-013	Switch lever	1
109	CM1224C-01-015	Switch cover	1
110	GB/T65	Screw M6×12	2
111	CM1224C-01-014	Eccentric block	2
112	GB/T77	Screw M6×6	3
113	GB/T70	Screw M6×12	2
114	CM1224C-01-016	Switch board	1
115	CM1237CHG-01-010	Bed	1
116	CM1224C-01-005	Sleeve	1
117	GB/T879	Spring pin 5×30	2
118	CM1237CHG-01-006	Longitudinal lead screw	1
119	CM1237CHG-01-007(2)	Rack (left)	1
120	CM1237CHG-01-007(1)	Rack (right)	1
121	GB/T70	Screw M6×20	5
122	GB/T879	Spring pin 5×30	4
123	CM1224C-01-002	Change gear shaft	1
124	CM1224C-01-001	Change gear bracket	1
125	CM1224C-01-003	Bearing sleeve	1
126	GB/T95	Washer 10	2
127	GB/T5780	Bolt M10×40	1
128	GB/T276	Bearing 6003-Z	2
129	CM1224C-01-004	Change gear	1
130	GB/T41	Nut M10	1
131	GB/T70	Screw M10×34	4
132	GB/T881	Taper pin with thread 8×75	2
133	CM1237CHG-01-010(1)	Gap	1
134	CM1224C-01-017	Stop pin	1
135	CZ1237G-02-059	Motor pulley	1
136	GB/T77-85	Screw M6×8	2
137	GB/T1096-79	Key 8×25	1

Index No.	Part No.	Description	QTY.
138	GB/T5780	Bolt M8×25	4
139	GB/T96	Washer 8	4
140	Y90L-4	Motor 1.5kw	1
141	CM1224C-02-042	Bolt	2
142	CM1224C-02-005	Motor seat	1
143	CM1224C-02-006	Motor rest	1
144	CZ1237A-00-001	Puller cover	1
145	GB/T5783	Bolt M12×90	1
146	GB/T6172	Nut M12	2
147	GB/T96	Washer 12	2
148	GB/T70-85	Screw M8×30	4
149	GB/T879	Spring pin 3×5	1
150	GB/T1096	Key B5×18	1
151	CM1224-06-005	Sleeve	1
152	CM1224-02-002	Arm	1
153	GB/T70	Screw M6×12	2
154	CM1224-07-004	Spring 1×6×22	1
155	GB/T78	Screw M8×12	1
156	CM1224-07-003	Cover	1
157	GB/T308	Steel ball 6	1
158	CM1224-07-006	Spring 1×6×9	1
159	GB/T77	Screw M8×10	1
160	CM1224-07-001	Lever	1
161	GB/T119	Pin B5×35	1
162	GB/T4141.14	Grip	1

Headstock Assembly

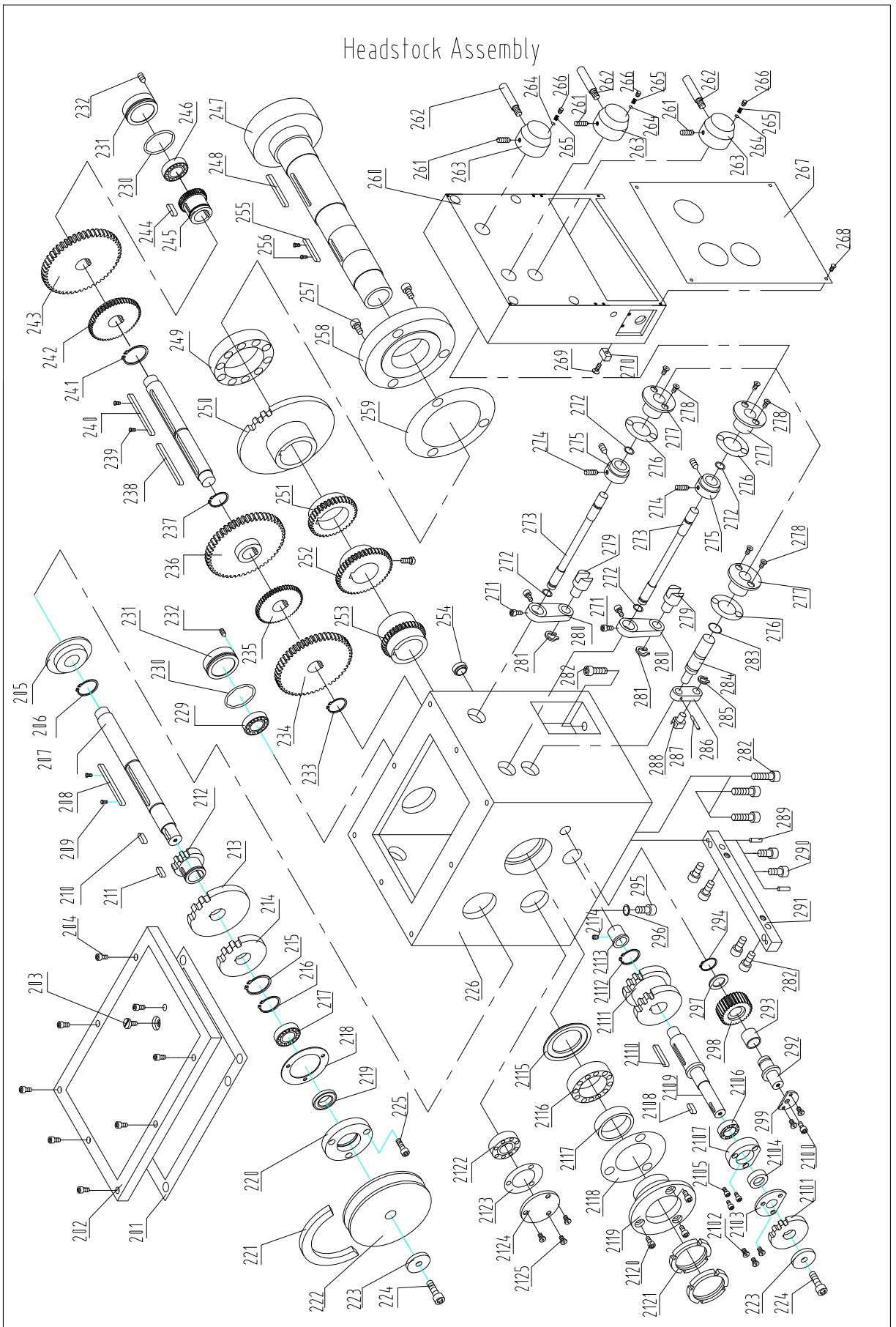

Index No.	Part No.	Description	QTY.
201	CZ1237G-02-055	Gasket	1
202	CZ1237A-02T01-001	Cover	1
203	CM1224C-03-034	Oil fill plug	1
204	GB/T70	Screw M6×25	8
205	CZ1237G-02-024	Round fork	1
206	GB/T894.2	Retaining ring (external) 25	1
207	CZ1237G-02-025	Input shaft	1
208	GB/T1096	Key 8×80	
209	GB/T65	Screw M3×8	2
210	GB/T1096	Key 5×14	1
211	GB/T1096	Key 8×20	1
212	CZ1237G-02-022	Gear	1
213	CZ1237G-02-021	Gear	1
214	CZ1237G-02-020	Gear	1
215	GB/T894.2	Retaining ring (external) 38	1
216	GB/T894.2	Retaining ring (external) 25	1
217	GB/T276	Bearing 6205P6	1
218	CZ1237G-02-017	Gasket	1
219	GB/T9877.1	Oil seal B25×40×7	1
220	CZ1237G-02-015	Cover	1
221	GB/T1174	B-Belt B914	1
222	CZ1237G-02-060	Pulley	1
223	CM1224C-03-008	Washer	2
224	GB/T70	Screw M6×14	2
225	GB/T70	Screw M6×20	3
226	CZ1237G-02-002	Headstock	1
229	GB/T276	Bearing 6204P6	1
230	GB/T7757.2	O-Ring gasket 43.7×1.8	2
231	CZ1237G-02-026	Plug	2
232	GB/T71	Screw M6×10	2
233	GB/T894.2	Retaining ring (external) 25	1
234	CZ1237G-02-013	Gear	1
235	CZ1237G-02-014	Gear	1
236	CZ1237G-02-23	Gear	1
237	GB/T894.2	Retaining ring (external) 25	1
238	GB/T1096	Key 8×80	1
239	GB/T65	Screw M3×8	2
240	GB/T1097	Key 8×80	1
241	Gb/t894.2	Retaining ring (external) 38	1
242	CZ1237G-02-028	Gear	1
243	CZ1237G-02-027	Gear	1

Index No.	Part No.	Description	QTY.
244	GB/T1096	Key 8×20	1
245	CZ1237G-02-029	Gear	1
246	GB/T276	Bearing 6204P6	1
247	CZ1237G-02-034	Spindle	1
248	GB/T1096	Key 8×80	1
249	GB/T297	Bearing 30211P5	1
250	CZ1237G-02-031	Gear	1
251	CZ1237G-02-033	Gear	1
252	CZ1237G-02-032	Gear	1
253	CZ1237G-02-037	Gear	1
254	GB/T1160	Oil level indicator	1
255	GB/T1096	Key 8×70	1
256	GB/T65	Screw M6×8	1
257	GB/T70	Screw M8×30	3
258	CZ1237G-02-035	Cover	1
259	CZ1237G-02-030	Gasket	1
260	CZ1237G-02T01-004	Inlaid block	1
261	GB/T78	Screw M8×14	3
262	CZ1237G-02-046	Handle	3
263	CZ1237G-02-045	Handle seat	3
264	GB/T308	Steel ball	3
265	GB/T2089	Spring 1×5×20	3
266	GB/T73	Screw M8×5	3
267	CZ1237G-02T01-006	Name plate	1
268	GB/T818	Screw M4×8	4
269	CZ1237G-02T01-002	Block	1
270	GB/T819	Screw M4×12	1
271	GB/T71	Screw M6×10	4
272	GB/T7757.2	O-Ring gasket	4
273	CZ1237G-02-043	Shaft	2
274	GB/T71	Screw M6×10	4
275	CZ1237G-02-054	Collar	2
276	CZ1237G-02-047	Gasket	3
277	CZ1237G-02-044	Fixing seat	3
278	GB/T819	Screw M5×10	6
279	CZ1237G-02-040	Fork	2
280	CZ1237G-02-039	Arm	2
281	GB/T894.2	Retaining ring (external) 15	2
282	GB/T70	Screw M10×35	6
283	GB/T7757.2	O-Ring gasket	1
284	CZ1237G-02-048	Shaft	1
285	GB/T894.2	Retaining ring (external) 10	1

286	CZ1237G-02-049	Arm	1
287	GB/T879	Spring pin 4×20	1
288	CZ1237G-02-050	Fork	1
Index No.	Part No.	Description	QTY.
289	GB/T119	Pin 8×26	2
290	GB/T70	Screw M10×30	4
291	CZ1237G-02-001	Adjusting bar	1
292	CZ1237G-02-005	Shaft	1
293	CZ1237G-02-007	Collar	1
294	GB/T894.2	Retaining ring (external) 20	1
295	GB/T70	Screw M10×16	1
296	GB/T7757.2	O-Ring gasket 10×1.8	1
297	CZ1237G-02-008	Washer	1
298	CZ1237G-02-006	Gear	1
299	CZ1237G-02-038	Cover	1
2100	GB/T819	Screw M5×10	3
2101	CZ1237G-02-042	Gear	1
2102	GB/T822	Screw M3×10	3
2103	CZ1237G-02-038	Cover	1
2104	GB/T9877.1	Oil seal FB20×35×7	1
2105	GB/T70	Screw M5×16	3
2106	GB/T276	Bearing 61804P6	1
2107	CZ1237G-02-056	Cover	1
2108	GB/T1096	Key 5×14	2
2109	CZ1237G-02-004	Shaft	1
2110	GB/T1096	Key 8×40	1
2111	CZ1237G-02-003	Gear	1
2112	GB/T894.2	Retain ring (external) 26	1
2113	CZ1237G-02-036	Sleeve	1
2114	GB/T71	Screw M6×10	1
2115	CZ1237G-02-009	Flashing ring	1
2116	GB/T297	Bearing 32010P6	1
2117	CZ1237G-02-053	Spacer	1
2118	CZ1237G-02-016	Gasket	1
2119	CZ1237G-02-010	Cover	1
2120	GB/T70	Screw M6×14	3
2121	GB/T812	Round nut M50×1.5	2
2122	GB/T276	Bearing 6205P6	1
2123	CZ1237G-02-019	Gasket	1
2124	CZ1237G-02-011	Cover	1
2125	GB/T819	Screw M5×10	3

OPENED GEAR BOX ASSEMBLY

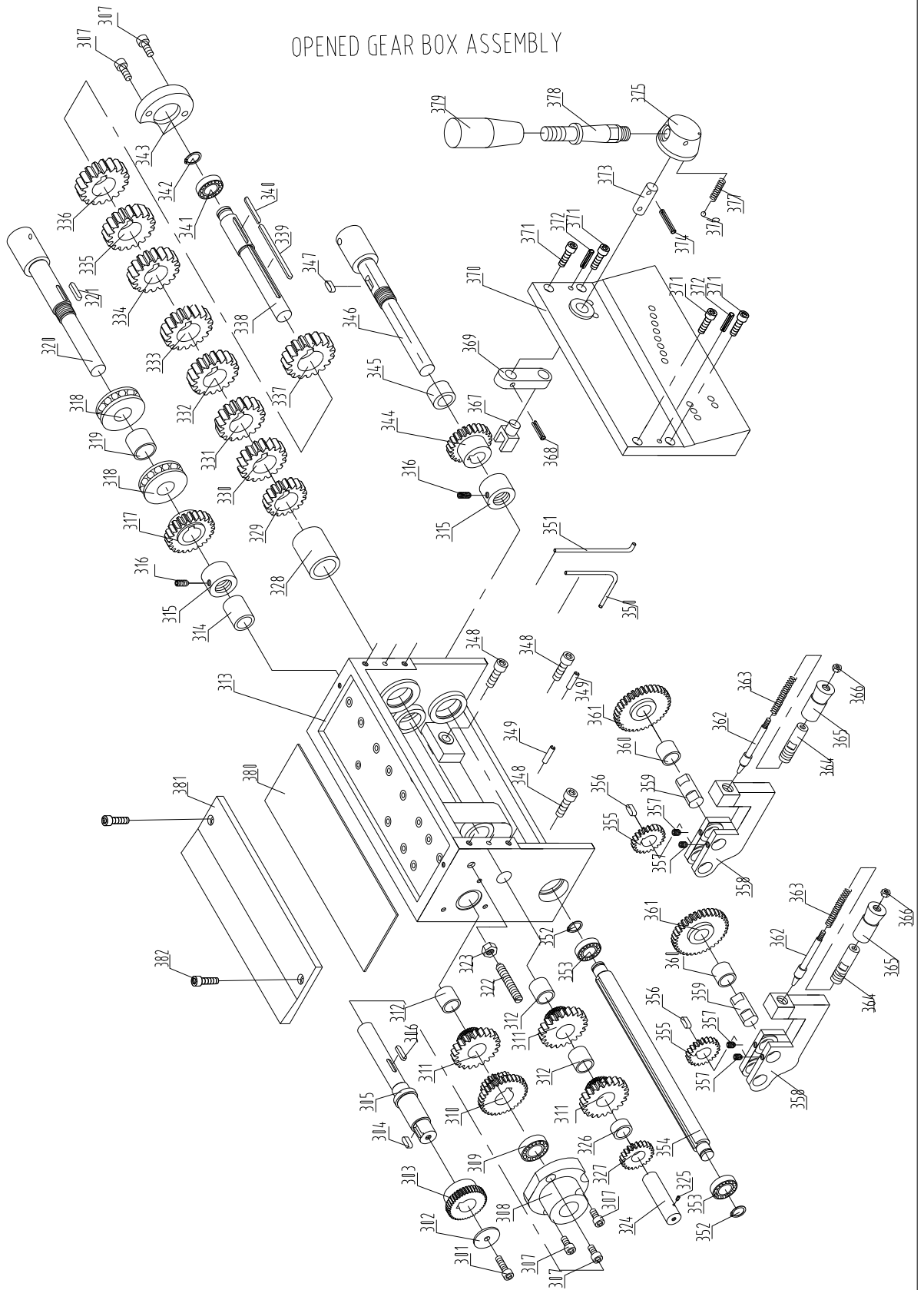

Index No.	Part No.	Description	Qty.
301	GB/T70	Screw M6×12	1
302	CM1224C-03-008	Washer	1
303	CM1224C-03-009	Gear	1
304	GB/T1096	Key 5×14	1
305	CM1224C-03-007	Shaft	1
306	GB/T1567	5×3×6	1
307	GB/T70	Screw M6×10	5
308	CM1224C-03-010	Bearing cover	1
309	GB/T276	Bearing 6003	1
310	CM1224C-03-013	Duplex gear	1
311	CM1224C-03-014	Duplex gear	3
312	CM1224C-03-012	Gear sleeve	3
313	CM1224C-03-033	Gear box	1
314	CM1224C-03-011	Sleeve	2
315	CM1224C-03-049	Nut	2
316	GB/T78	Screw M6×6	2
317	CM1224C-03-025	Gear	1
318	GB/T301	Bearing 51104	2
319	CM1224C-03-026	Sleeve	1
320	CM1224C-03-027	Shaft	1
321	GB/T1096	Key 6×16	2
322	GB/T73	Screw M8×35	1
323	GB/T41	Nut M8	1
324	CM1224C-03-041	Shaft	1
325	GB/T78	Screw M6×6	1
326	CM1224C-03-015	Gear	1
327	CM1224C-03-016	Gear sleeve	1
328	CM1224C-03-017	Gear	1
329	CM1224C-03-018	Gear	1
330	CM1224C-03-019	Gear	1
331	CM1224C-03-020	Gear	1
332	CM1224C-03-021	Gear	
333	CM1224C-03-022	Gear	
334	CM1224C-03-023	Gear	
335	CM1224C-03-024	Gear	
336	CM1224C-03-025	Gear	
337	CM1224C-03-029	Shaft	1
338	CM1224C-03-051	Key 5×74	
339	GB/T1096	Key 6×32	1
340	GB/T276	Bearing 6002-z	1

Index No.	Part No.	Description	Qty.
341	GB/T894.1	Retain ring (external) 15	1
342	CM1224C-03-050	Cover	1
344	CM1224C-03-032	Gear	1
345	CM1224C-03-031	Sleeve	1
346	CM1224C-03-030	Shaft	3
348	GB/T70	Screw M8×25	4
349	GB/T879	Pin 5×20	1
350	CM1224C-03-042	Oil pipe	1
351	CM1224C-03-043	Oil pipe	2
352	GB/T894.1	Retain ring	2
353	GB/T276	Bearing 6201-z	1
354	CM1224C-03-005	Shaft	2
355	CM1224C-03-006	Gear	2
356	GB/T1096	Key 5×14	4
357	GB/T77	Screw M6×6	2
358	CM1224C-03-001	Handle seat	2
359	CM1224C-03-003	Shaft	2
360	CM1224C-03-004	Gear sleeve	2
361	CM1224C-03-002	Gear	2
362	CM1224C-03-045	Axle of gripper	2
363	CM1224C-03-046	Spring	2
364	CM1224C-03-047	Sleeve of gripper	2
365	CM1224C-03-044	Lever	2
366	GB/T923	Nut M6	1
367	CM1224C-03-036	Fork	1
368	GB/T879	Pin 5×24	1
369	CM1224C-03-038	Arm	1
370	CM1224C-03-040	Front cover of gear box	4
371	GB/T70	Screw M6×16	1
272	GB/T879	Pin 5×20	2
373	CM1224C-03-039	Shaft	1
374	GB/T879	Pin 5×40	1
375	CM1224C-03-048	Knob	1
376	GB/T308	Steel ball 6	1
377	GB/T2089	Spring 1×4.5×16	1
378	CM1224C-04-003	Lever	1
379	GB/T4141.14	Lever grip BM10×50	1
380	CM1224C-03-037	Gasket	1
381	CZ300A-03-004	Cover	1
382	GB/T70	Screw M6×12	2

CLOSED GEAR BOX ASSEMBLY

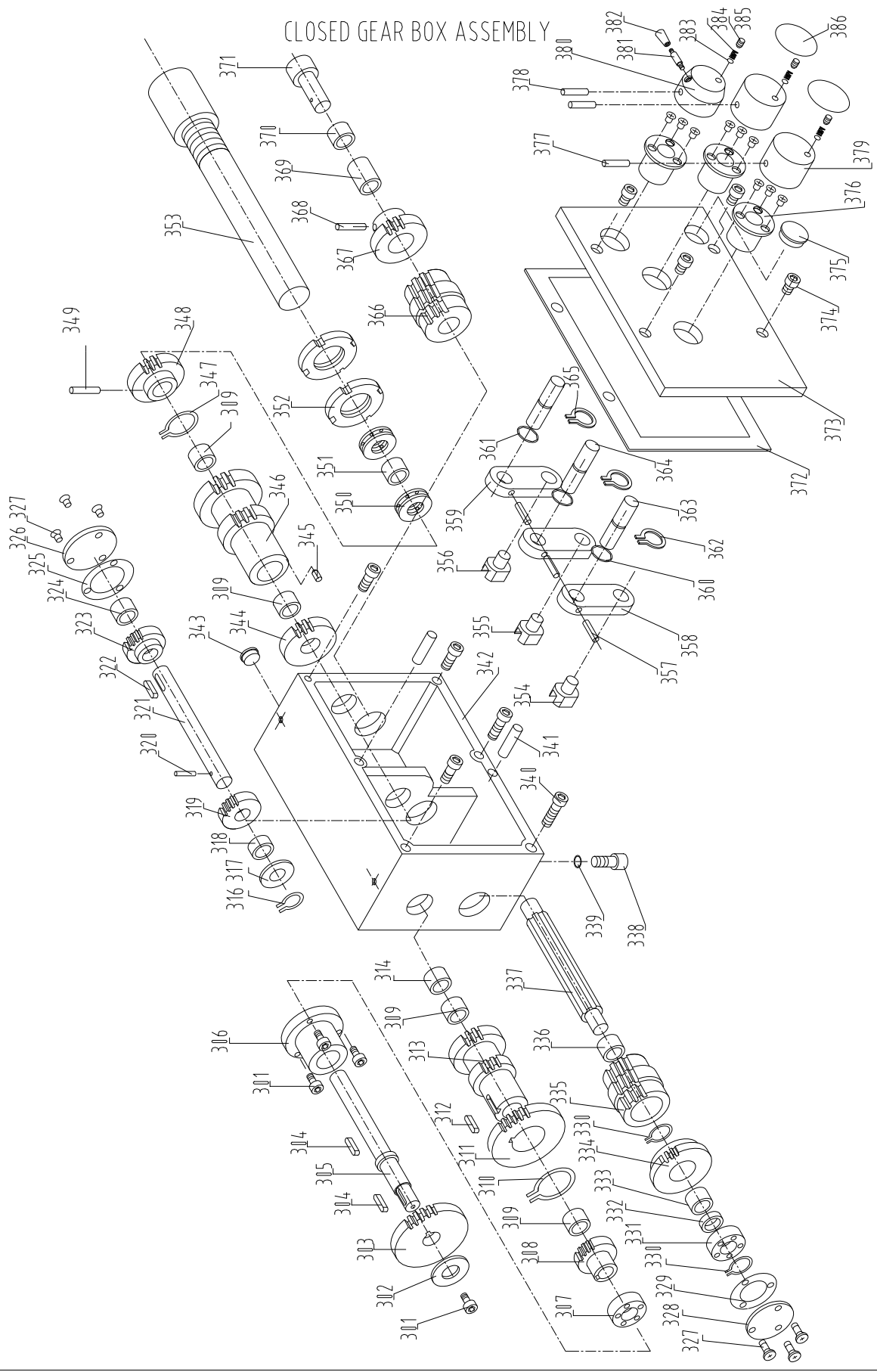

Index No.	Part No.	Description	Qty.
301	GB/T70-85	Screw M6×12	4
302	CM1224C-03-008	Washer	1
303	CZ300A-03-001	Gear M=1.25,Z=30,60,64,70	4
304	GB/T1096	Key 5×14	1
305	CZ300A-03-017	Inputting shaft	1
306	CM1224C-03-010	Bearing cover	1
307	GB/T276-94	Bearing6003	1
308	CZ300A-03-018	Gear M=2,Z=18	1
309	CZ300A-03-026	Sleeve	2
310	GB/T894.1-85	Retain ring (external) 32	1
311	CZ300A-03-020	Duplex gear M=2,Z=36/27	1
312	Gb/t1096	Key 6×16	1
313	CZ300A-03-021	Duplex gear M=2,z=22/25	1
314	CZ300A-03-042	Sleeve	1
316	GB/T894.1-85	Retain ring (external) 15	1
317	CZ300A-03-041	Adjusting washer	1
318	CZ300A-03-036	Sleeve	1
319	CZ300A-03-039	Gear	1
320	GB/T879	Pin 5×28	1
321	CZ300A-03-038	Shaft	1
322	GB/T1096	Key 5×28	1
323	CZ300A-03-037	Gear M=2,Z=19	1
324	CZ300A-03-036	Sleeve	1
325	CZ300A-03-035	Gasket	1
326	CZ300A-03-034	Cover	1
327	GB/T819	Screw M5×10	3
328	CZ300A-03-046	Cover	1
329	CZ300A-03-047	Gasket	1
330	GB/T894.1-85	Retain ring (external) 15	1
331	GB/T276-94	Bearing 6002	1
332	CZ300A-03-019	Sleeve	1
333	CZ300A-03-044	Sleeve	1
334	CZ300A-03-043	Duplex gear M=2, Z=18/36	1
335	CZ300A-03-022	Gears M=2,Z=27/33/30	1
336	CZ300A-03-042	Sleeve	1
337	CZ300A-03-033	Shaft	1
338	GB/T70-85	Screw M10×10	1
339	GB/T3452.1	Gasket ring 10×1.8	1
340	GB/T70-85	Screw M8×60	5

341	GB/T879		2
		<i>Pin 5×20</i>	
342	CZ300A-03-040	Box	1
343	CZ300A-03-034	Oil cover	1
344	CZ300A-03-024	Gear	1
345	GB/T879	Pin 5×12	3
346	CZ300A-03-025	Duplex M=2,Z=18/36	1
347	GB/T896-86	Retain ring (external) 12	1
348	CZ300A-03-030	Gear M=2,z=27	1
349	GB/T879	Pin 5×30	1
350	GB/T301	Bearing 8103	2
351	CZ300A-03-031	Sleeve	1
352	GB/T810	Nut M20×1.5	2
353	CZ300A-03-008	Shaft	1
354	CZ300A-03-052	Fork	1
355	CZ300A-03-053	Fork	1
356	CZ300A-03-012	Fork	1
357	GB/T879	Pin 5×25	3
358	CZ300A-03-050	Arm	2
359	CZ300A-03-013	Arm	1
360	GB/T3452.1	Gasket ring 8.75×1.8	2
361	GB/T3452.1	Gasket ring 8.75×1.9	1
362	GB/T894	Retain ring (external) 12	2
363	CZ300A-03-049	Shaft	1
364	CZ300A-03-014	Shaft	2
365	GB/T894	Retain ring (external) 10	1
366	CZ300A-03-027	Gears M=2,Z=27/36/18	1
367	CZ300A-03-028	Gear M=2,Z=32	1
368	GB/T879	Pin 5×20	1
369	CZ300A-03-029	Sleeve	1
370	CZ300A-03-032	Sleeve	1
371	CZ300A-03-009	Shaft	1
372	CZ300A-03-010	Gasket	1
373	CZ300A-03-051	Cover	1
374	GB/T70	Screw M8×16	4
375	JB/T7941.1	Oil level indicator 16	1
376	CZ300A-02-044	Fixing seat	3
377	GB/T879	Pin 5×45	2
378	GB/T879	Pin 5×45	1
379	CZ300A-02-047	Handle	2
380	CZ300A-03-016	Seat of lever	1

381	CM1224C-04-013	Lever		1
382	JB/T7271.5	Grip of lever		1
383	GB/T308	Steel ball 6.5		3
384	GB/T2089	Compression spring	1×5×20	3
385	GB/T73	Screw	M8×5	3
386	CZ300A-02-048	Indicator		2

APRON ASSEMBLY

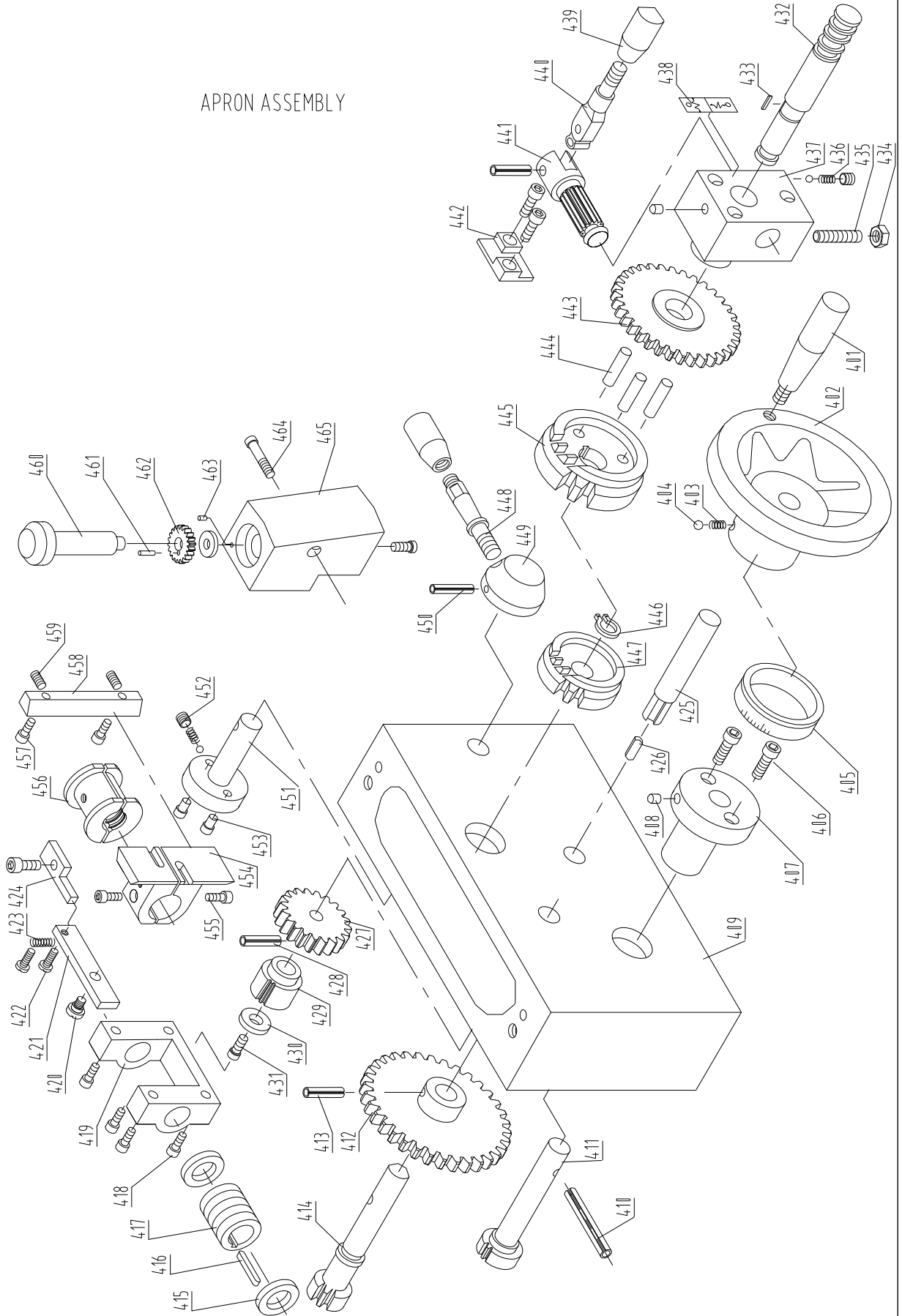

Index No.	Part No.	Description	Qty.
401	JB/T7270.1	Handle BM8×63	1
402	CM1224-04-011	Handwheel	1
403	CM1224-06-007	Spring	2
404	GB/T308	Steel ball 6	3
405	CM1224-04-013	Indicate ring	1
406	GB/T70	Screw M6×16	3
407	CM1224-04-014	Handwheel seat	1
408	GB/T7940.4	Oil cup 6	2
409	CM1224-04-015	Box	1
410	GB/T879	Pin 5×60	
411	CM1224-04-012	Gear	1
412	CM1224-04-016	Gear	1
413	GB/T879	Pin 5×30	1
414	CM1224-04-010	Shaft	1
415	CM1224-04-037	Washer	2
416	GB/T1096	Key 5×32	1
417	CM1224-04-022	Worm	1
418	GB/T70	Screw M6×25	
419	CM1224-04-021	Nut support	1
420	GB/T830	Screw M6×6	
421	CM1224-04-035	Safe pin	1
422	GB/T65	Screw M4×14	
423	CM1224-04-034	Spring	1
424	CM1224-04-032	Block	1
425	CM1224-04-007	Arbor	1
426	GB/T1096	Key 4×20	1
427	CM1224-04-006	Gear	1
428	GB/T879	Pin 5×24	2
429	CM1224-04-023	Worm	1
430	CM1224-04-031	Washer	2
431	GB/T70	Screw M6×12	4
432	CM1224-04-020	Shaft	1
433	GB/T1096	Key 4×8	1
434	GB/T6170	Nut M8	1
435	GB/T75	Screw M8×35	1
436	CM1224-04-038	Spring	2
437	CM1224-04-017	Change lever seat	1
438	CM1224-04-011	Feeding plate	1
439	JB/T7271.5	Grip BM10×50	1
440	CM1224-04-001	Change lever	1
441	CM1224-04-018	Change rod	1

Index No.	Part No.	Description	Qty.
442	CM1224-04-002	Safe guide piece	1
443	CM1224-04-008	Gear	1
444	GB/T119	Pin A6×30	3
445	CM1224-04-009	Gear	1
446	GB/T894.1	Retain ring (external) 16	1
447	CM1224-04-019	Clutch	1
448	CM1224-04-003	Handle	1
449	CM1224-04-036	Knob	1
450	GB/T879	Pin 5×40	1
451	CM1224-04-004	Rod	1
452	GB/T77	Screw M8×8	2
453	CM1224-04-024	Pin	2
454	CM1224-04-026	Half nut seat	1
455	GB/T70	Screw M6×8	2
456	CM1224-04-025	Half nut	1
457	GB/T70	Screw M5×16	2
458	CM1224-04-029	Pressure bar	1
459	GB/T78	Screw M6×12	2
460	CM1224-04-028	Indicate arbor	1
461	GB/T119	Pin 3×12	1
462	CM1224-04-030	Gear	1
463	GB/T827	Rivet 2.5×5	1
464	GB/T70	Screw M6×45	1
465	CM1224-04-027	Threading seat	1

SADDLE ASSEMBLY

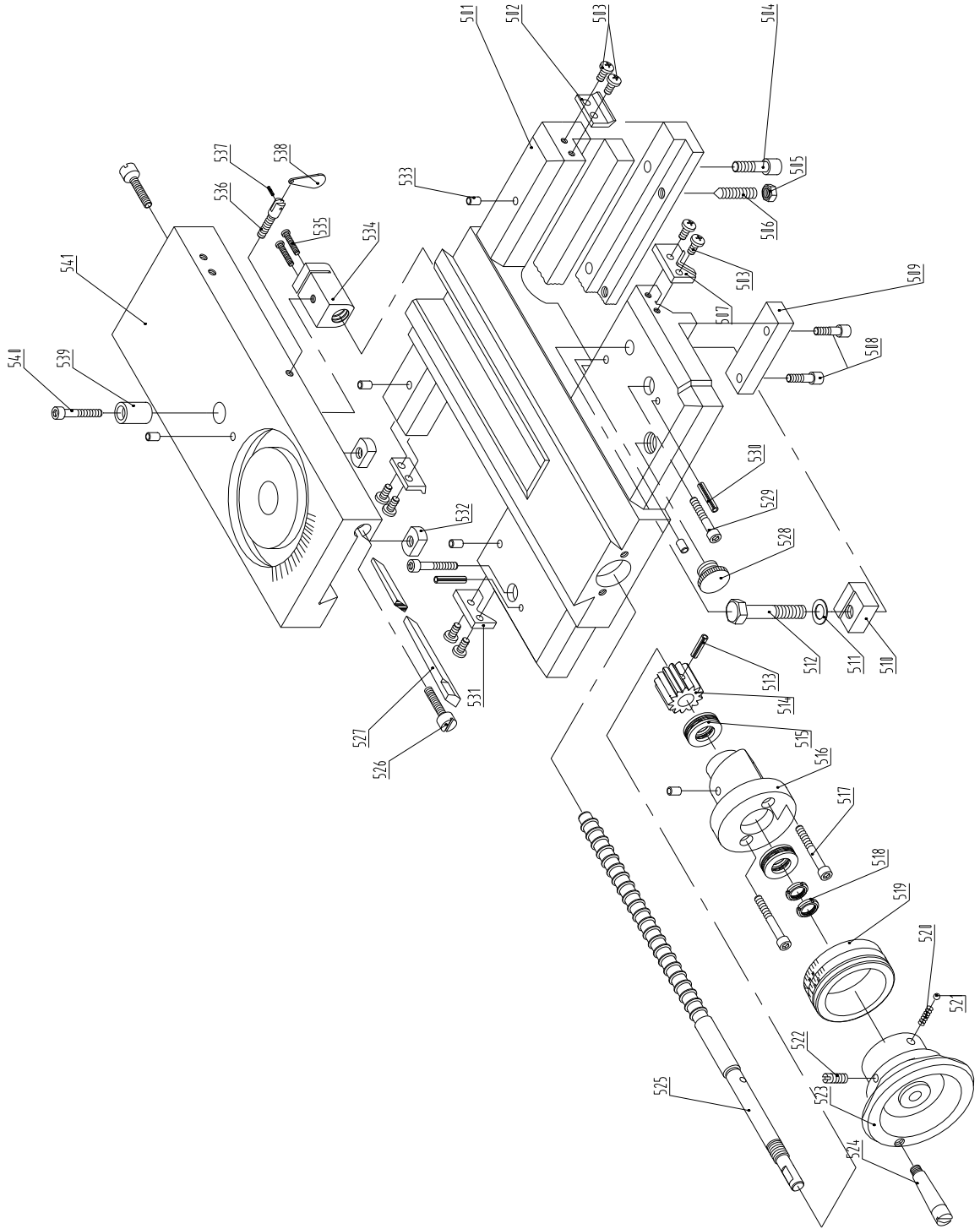

Index No.	Part No.	Description	QTY.
501	CM1224C-05-003	Saddle	1
502	CM1224C-05-044	Wiper	2
503	GB/T818	Screw M5×12	8
504	GB/T70	Screw M8×25	3
505	GB/T41	Nut M8	3
506	GB/T78	Screw M8×22	3
507	CM1224C-05-041	Wiper	1
508	GB/T70	Screw M6×16	4
509	CM1224C-05-040	Block slide	2
510	CM1224C-05-032	Locking block	1
511	GB/T95	Washer 10	1
512	GB/T5780	Bolt M10×60	1
513	GB/T879	Pin 5×20	1
514	CM1224C-05-039	Gear	1
515	GB/T301	Bearing 51101	2
516	CM1224C-05-038	Lead screw seat	1
517	GB/T70	Screw M6×45	2
518	GB/T810	Nut M12×1.25	2
519	CM1224C-05-037	Graduation collar	1
520	CM1224C-06-007	Compressing spring	2
521	GB/T308	Steel ball 6	1
522	GB/T77	Screw M6×16	1
523	CM1224C-05-023	Handwheel	1
524	CM1224C-05-024	Handle	1
525	CM1224C-05-004	Lead screw of saddle	1
526	CM1224C-05-034	Adjusting screw	2
527	CM1224C-05-035	Gib	1
528	CM1224C-03-034	Plug	1
529	GB/T70	Screw M8×30	2
530	GB/T879	Pin 5×35	2
531	CM1224C-05-042	Wiper	1
532	CM1224C-05-008	Fixing block	2
533	JB/T7940.1	Oil cup 6	6
534	CM1224C-05-006	Lead screw nut	1
535	GB/T818	Screw M4×20	2
536	CM1224C-05-022A	Locking screw	2
537	GB/T879	Pin 2×8	2
538	CM1224C-05-022B	Locking lever	2
539	CM1224C-05-007	Fixing seat	1
540	GB/T70	Screw M6×20	1
541	CM1224C-05-005	Cross slide	1

TOOL POST ASSEMBLY

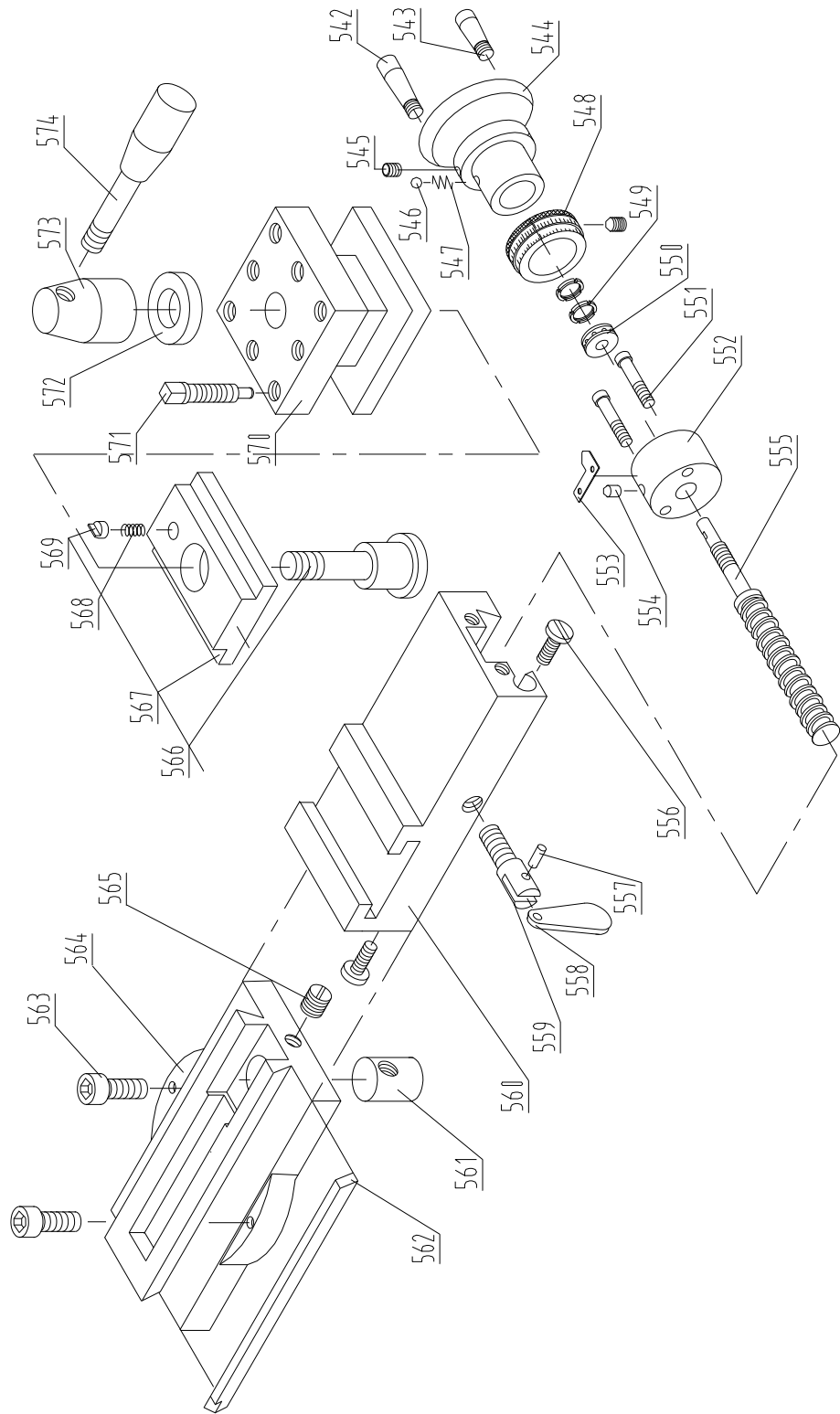

Index No.	Part No.	Description	QTY.
542	CM1224C-05-031	Handle	1
543	CM1224C-05-030	Handle	1
544	CM1224C-05-029	Handwheel	1
545	GB/T77	Screw M6×16	2
546	GB/T308	Steel ball6	1
547	CM1224C-06-007	Pressure spring	1
548	CM1224C-05-028	Graduation collar	1
549	GB/T810	Nut M10×1	2
550	GB/T301	Bearing 51100	1
551	GB/T70	Screw M4×30	2
552	CM1224C-05-027	Leadscrew seat	1
553	CM1224C-00-006	Indicator plate	1
554	JB/T7940.4	Oil cup 6	1
555	CM1224C-05-025	Leadscrew	1
556	CM1224C-05-020	Adjusting screw	2
557	GB/T879	Pin 2×8	2
558	CM1224C-05-022(B)	Clamping knob	1
559	CM1224C-05-022(A)	Clamping screw	1
560	CM1224C-05-010	Base of tool post	1
561	CM1224C-05-026	Leadscrew nut	1
562	CM1224C-05-019	Gib	1
563	GB/T70	Screw M8×24	2
564	CM1224C-05-009	Swivel base	1
565	GB/T78	Screw M6×12	1
566	CM1224C-05-016	Locking screw	1
567	CM1224C-05-043	T-block	1
568	CM1224C-05-011	Compressing spring	1
569	CM1224C-05-012	Locating block	1
570	CM1224C-05-014	Tool post	1
571	CM1224C-05-013	Screw	8
572	CM1224C-05-015	Washer	1
573	CM1224C-05-017	Lever	1
574	CM1224C-05-018	Handle	1

TAILSTOCK ASSEMBLY

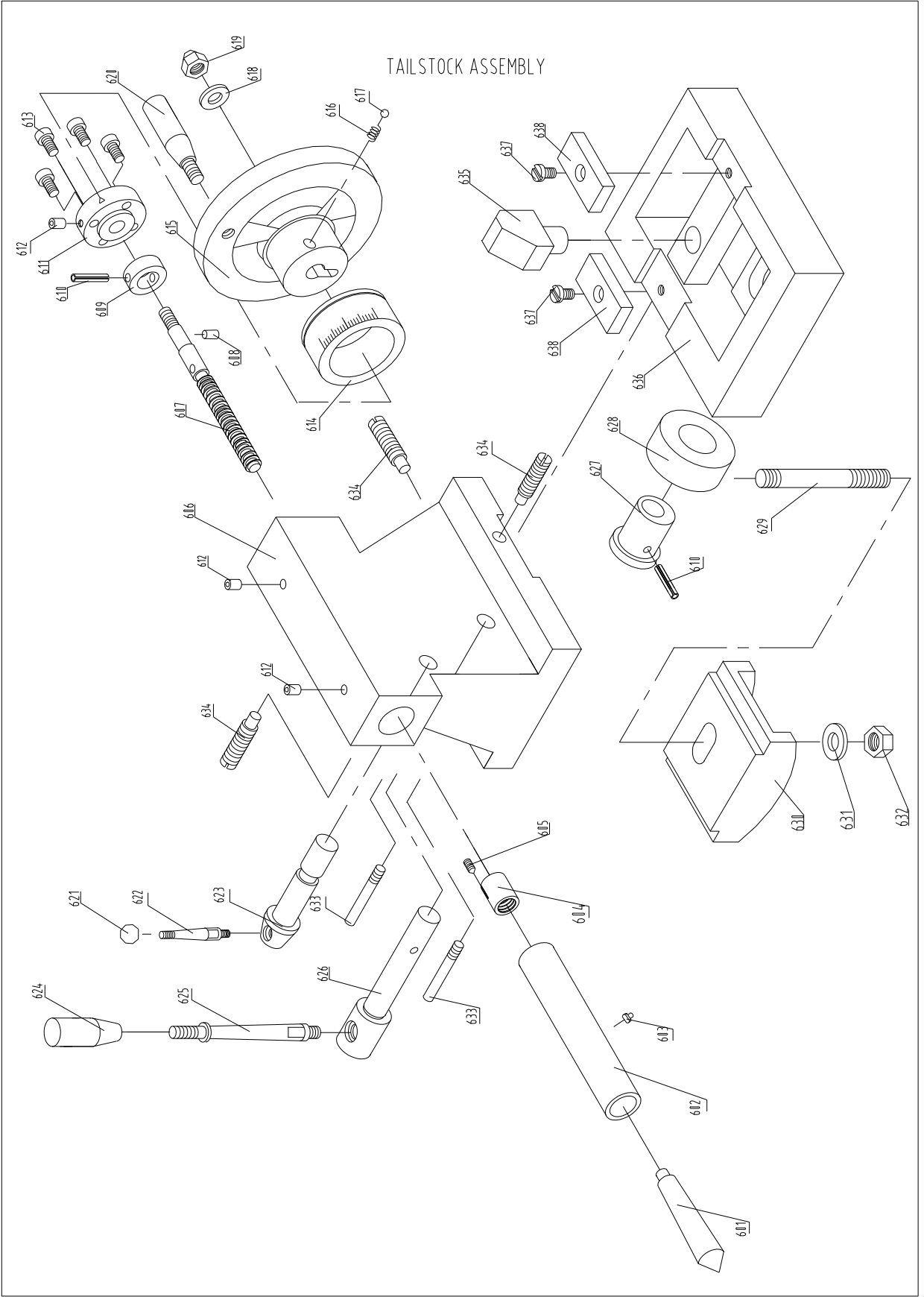

Index No.	Part No.	Description	QTY.
601	GB/T9204.1	Center M.T.3.	1
602	CM1224C-06-002	Tailstock quill	1
603	CM1224C-06-021	T-Key	1
604	CM1224C-06-004	Nut of leadscrew	1
605	GB/T78	Screw M6×10	1
606	CM1224C-06-001	Tailstock	1
607	CM1224C-06-003	Leadscrew	1
608	GB/T119	Pin 5×8	1
609	CM1224C-06-022	Sleeve	1
610	GB/T879	Spring pin5×24	2
611	CM1224C-06-005	Leadscrew seat	1
612	JB/T7940.4	Oil cup	3
613	GB/T70	Screw M6×16	4
614	CM1224C-06-006	Graduation collar	1
615	CM1224C-06-016	Handwheel	1
616	CM1224C-06-007	Spring	1
617	GB/T308	Steel ball 6	1
618	GB/T97.1	Washer 10	1
619	GB/T923	Nut M10	1
620	GB/T4141.1	Handle BM8×63	1
621	GB/T4141.11	Lever ball M6×20	1
622	CM1224C-06-008	Lever	1
623	CM1224C-06-009	Eccentric axle	1
624	GB/T4141.14	Lever grip M10×50	1
625	CM1224C-06-015	Lever	1
626	CM1224C-06-014	Clamping shaft	1
627	CM1224C-06-011	Sleeve of eccentric axle	1
628	CM1224C-06-010	Sleeve	1
629	CM1224C-06-019	Double end bolt	1
630	CM1224C-06-018	Fixing block	1
631	GB/T97.1	Washer 12	1
632	GB/T6170	Nut M12	1
633	CM1224C-06-013	Clamping axle	2
634	GB/T75	Screw M10×40	3
635	CM1224C-06-017	Fixing bracket	1
636	CM1224C-06-020	Base plate	1
637	GB/T68	Screw M6×12	2
638	CM1224C-06-012	Fixing block	2

ELECTRIC ASSEMBLY

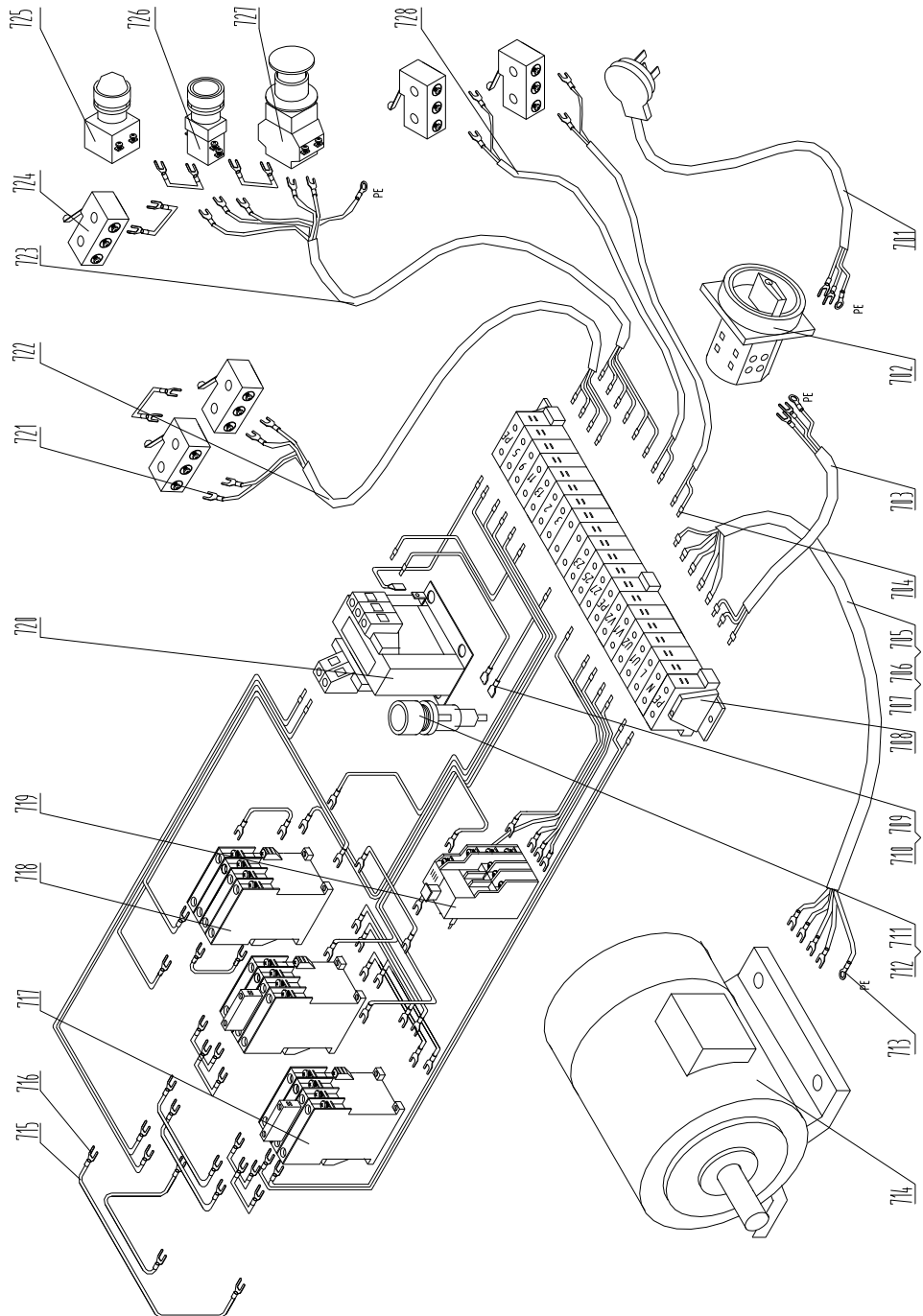

Index No.	Part No.	Description	QTY.
701	RVV3×25	Plug wire	
702	DTH13-20	Finger-protected switch	
703	RVV×25	Switch cord	
704		“needle” connector wire	
705		Metal hose Φ 10	
706	BVR1.5	Copper wire	
707	BVR1	Copper wire	
708	JXB15-19	Wiring panel	
709		Plug in unit 4.8	
710		Sleeve of plug in unit	
711	BLX	Fuse core 2A	
712	BLX	Fuse	
713	OT1.5-4	Connector wire	
714	YL90L4	Motor	
715	BVR1.5	Copper wire	
716	UT1.5-4	Connector wire	
717	B16	Contactora	
718	CJX2	Contactora	
719	T16	Thermal relay	
720	JBK5-63	Transformer	
721	UT1-3	Connector wire	
722	RVV5×1	Wire, 5 core in	
723	RVV6×1	Wire, 6 core in	
724	LXW5-11	Micro-switch	
725	AD11	Indicator light	
726	LA19	Green button	
727	LAY3	Emergency switch	
728	RVV2×1	Wire, 2 core in	

FOLLOW REST ASSEMBLY

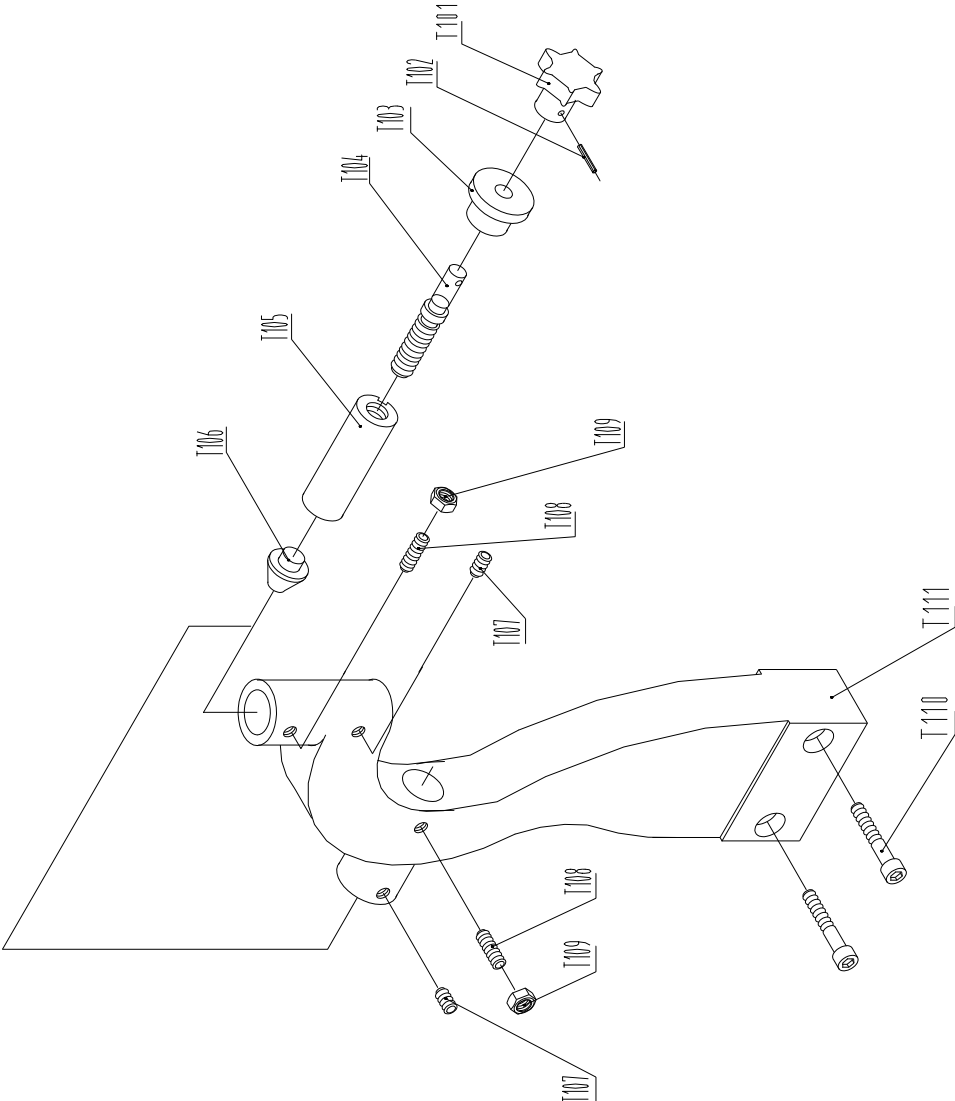

Index No.	Part No.	Description	QTY.
T101	JB/T727404	Star handle M8×30	2
T102	GB/T879	Pin 3×16	2
T103	CM1224C-05T02-003	Collar	2
T104	CM1224C-05T02-002	Adjusting screw	2
T105	CM1224C-05T02-004	Sleeve	2
T106	CM1224C-05T02-005	Clamping block	2
T107	GB/T78	Screw M6×8	2
T108	GB/T71	Screw M6×16	2
T109	GB/T6170	Nut M6	2
T110	GB/T70	Screw M8×35	2
T111	CM1224C-05T02-002	Follow rest	1

STEADY REST ASSEMBLY

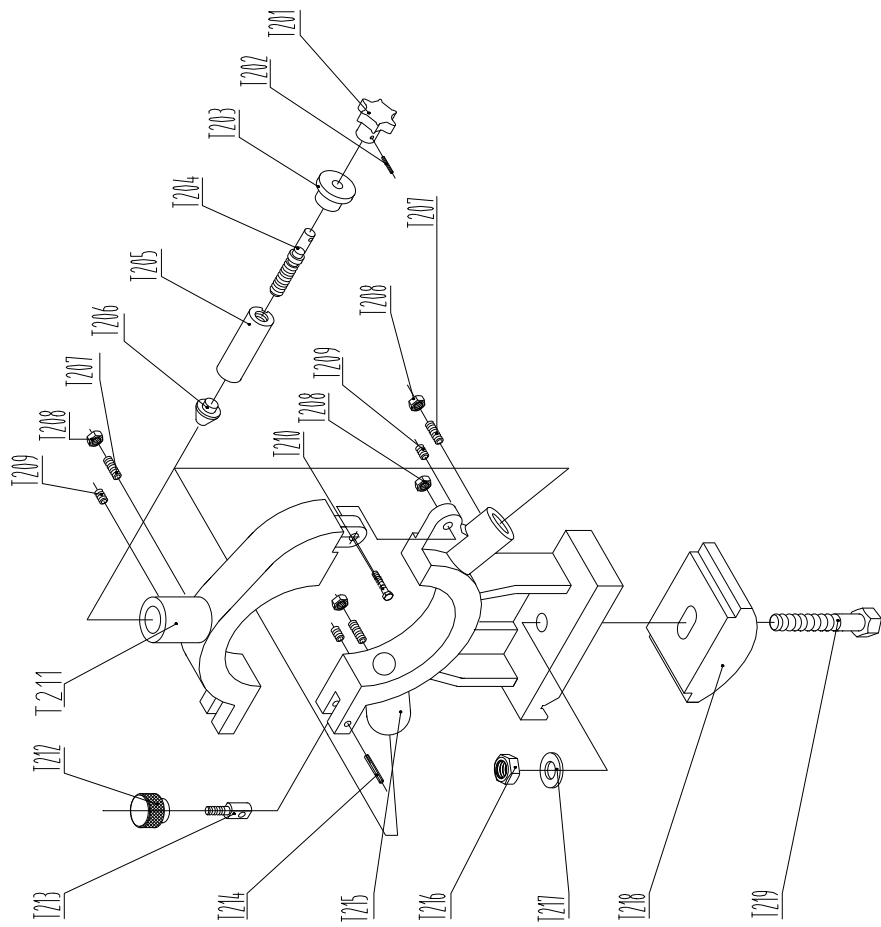

Index No.	Part No.	Description	QTY.
T201	JB/T7274.4	Star handle M8×30	3
T202	GB/T879	Pin 3×16	3
T203	CM1224C-05T02-003	Collar	3
T204	CM1224C-05T02-002	Adjusting screw	3
T205	CM1224C-05T02-004	Sleeve	3
T206	CM1224C-05T02-005	Clamping block	3
T207	GB/T71	Screw M6×16	3
T208	GB/T6170	Nut M6	4
T209	GB/T78	Screw M6×8	3
T210	GB/T27	Bolt M6×25	3
T211	CM1224C-05T03-003	Cover of steady rest	1
T212	CM1224C-05T03-002	Knob	1
T213	CM1224C-05T03-001	Lever	
T214	GB/T879	Pin 5×30	1
T215	CM1224C-05T03-004	Base of steady rest	1
T216	GB/T41	Nut M12	1
T217	GB/T95	Washer 12	1
T218	CM1224C-06-018	Fixing plate	1
T219	GB/T5780	Bolt M12×70	1