

# COMPACT STOPPER CYLINDER

Compact stopper cylinders designed for stopping moving parts or chucks.

- With or without magnet execution
- Single-acting, oversize extended piston rod
- Can be also used as double-acting with spring return
- Fixing centre distances to ISO 15552 for Ø 32, Ø 50, Ø 80 and French standard NFE 49-004-1 and 2 (UNITOP).

In the relevant cylinder slots, it is possible to mount retracting magnetic sensor.



 Chuck impact direction

TECHNICAL DATA	
Max operating pressure	bar 10 MPa 1 psi 145
Temperature range	°C -10 to +80
Fluid	Unlubricated air. Lubrication, if used, must be continuous
Stroke bore	mm Ø 20 x15; Ø 32 x 20; Ø50 x 30; Ø 80 x 30; Ø 80 x 40 a with NFE 49-004-1 and 2 fixing centre distances (UNITOP) mm Ø 32 x 20; Ø 50 x 30; Ø 80 x 30; Ø 80 x 40 with ISO 15552 fixing centre distances
Design	With profile, heads with screws
Versions	Single-acting extended rod, Can be also used as double-acting with spring return
Magnet for sensors	All versions come complete with magnet. Supplied without magnet on request
Inrush pressure	bar Ø 20: 1.2; Ø 32-50: 1; Ø 80: 0.5
Weights	See page 1-9
Notes	For correct operation, it is advisable to use 50 µm filtered air

## COMPONENTS Ø 20

- ① PISTON ROD: Stainless steel, thick chromed
- ② HEAD: extruded anodised aluminium alloy
- ③ BARREL: drawn anodised and calibrated aluminium alloy
- ④ PISTON GASKET: polyurethane
- ⑤ MAGNET: neodymium-plastic
- ⑥ PISTON ROD GASKET: polyurethane
- ⑦ GUIDE BUSHING: steel strip with bronze and PTFE insert
- ⑧ STATIC O-RINGS: NBR
- ⑨ SECURING SCREWS: zinc-plated steel
- ⑩ RETURN SPRING: spring stainless steel
- ⑪ WHEEL: zinc-plated steel

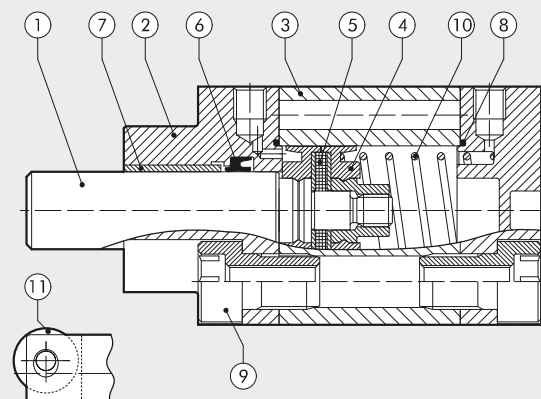

COMPONENTS Ø 32, Ø 50, Ø 80

- ① PISTON ROD: Stainless steel, thick chromed
- ② HEAD: extruded anodised aluminium alloy
- ③ BARREL: drawn anodised and calibrated aluminium alloy
- ④ PISTON GASKET: polyurethane
- ⑤ MAGNET: Ø 32 neodymium-plastic - Ø 50 to 80 plastoferrite
- ⑥ PISTON ROD GASKET: polyurethane
- ⑦ GUIDE BUSHING: steel strip with bronze and PTFE insert.
- ⑧ STATIC O-rings: NBR
- ⑨ SECURING SCREWS: zinc-plated steel
- ⑩ RETURN SPRING: spring stainless steel
- ⑪ WHEEL: zinc-plated steel

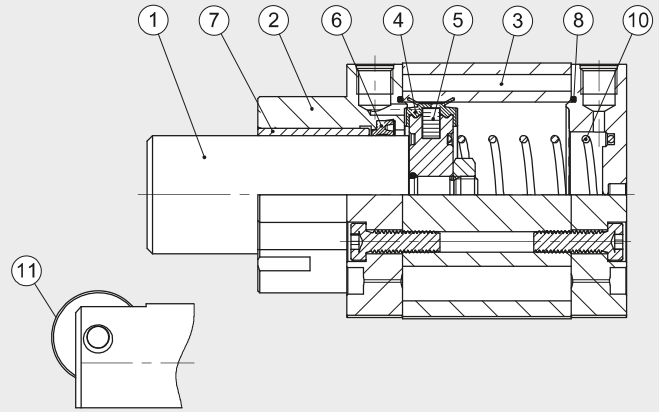

COMPACT STOPPER CYLINDER FIXING OPTIONS

- Ⓐ Fixing with screws, using the thread in the rear heads
- Ⓑ Direct fixing from above using long through screws or tie rods. Non-magnetic stainless steel must be used (e.g. AISI 304)
- Ⓒ Fixing with screws, using the thread in the front heads.
- Ⓓ Fixing using flange fixed onto the cylinder.

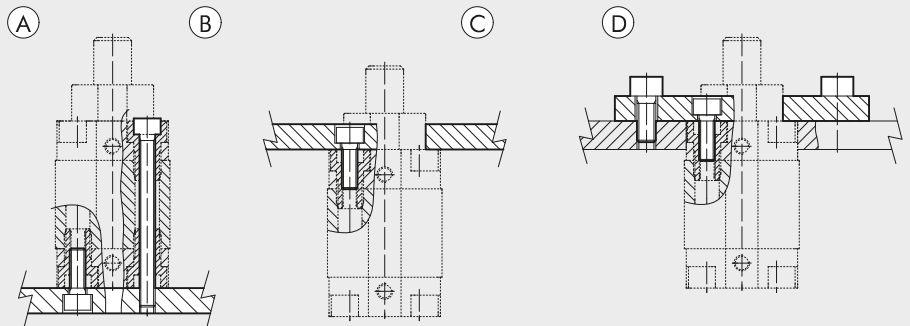

FORCE OF SPRINGS IN COMPACT STOPPER CYLINDERS (THEORETICAL)

Stroke bore	Ø 20 x 15	Ø 32 x 20	Ø 50 x 30	Ø 80 x 30	Ø 80 x 40
Min. load (N)	13.7	22.4	50.2	97.9	71.0
Max. load (N)	21.2	36.0	115.9	178.5	178.5

LOAD GRAPH

TRUNNION VERSION

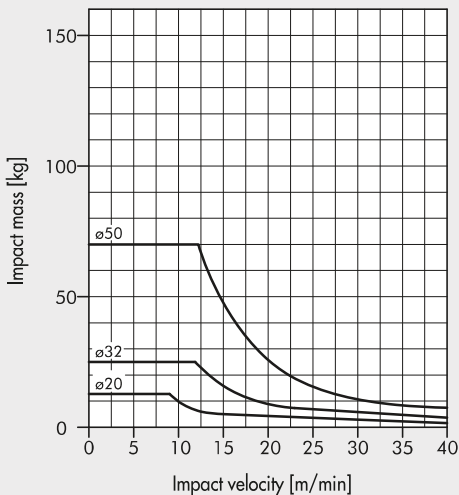

ROLLER VERSION

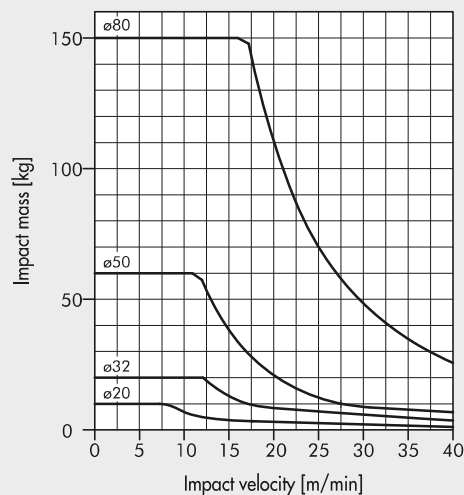

With stopper cylinders it is important to keep to the values shown in the graph to prevent early breakage of the mechanical parts. The values shown are only valid with about 1 mm plastic deformation (stopper on chuck).

**Ø 20 STROKE 15 mm TRUNNION VERSION**

1 = SENSOR SLOT

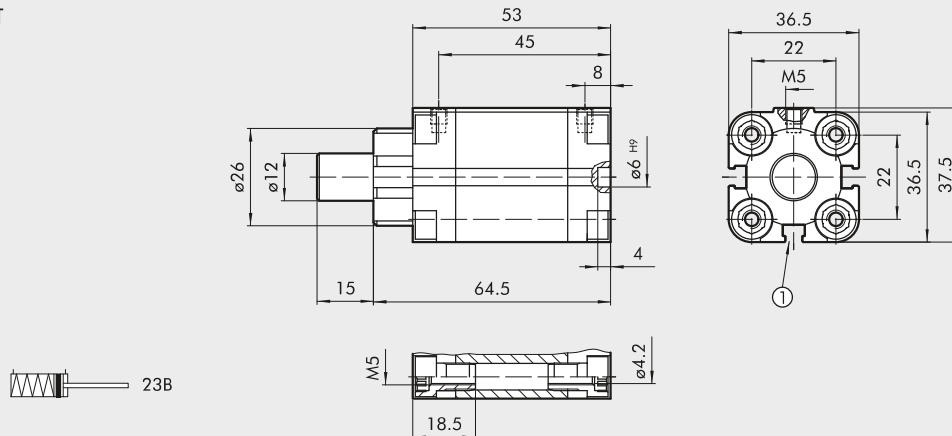

Code	Description
23B0200015XP	Compact stopper cylinder, trunnion Ø 20, stroke 15
23B5200015XP	Compact stopper cylinder, trunnion Ø 20, stroke 15 (non-magnetic version)

**Ø 32 STROKE 20 mm; Ø 50 STROKE 30 mm TRUNNION VERSION**

1 = SENSOR SLOT  
8 = SEAT FOR DIN 7984 SCREWS

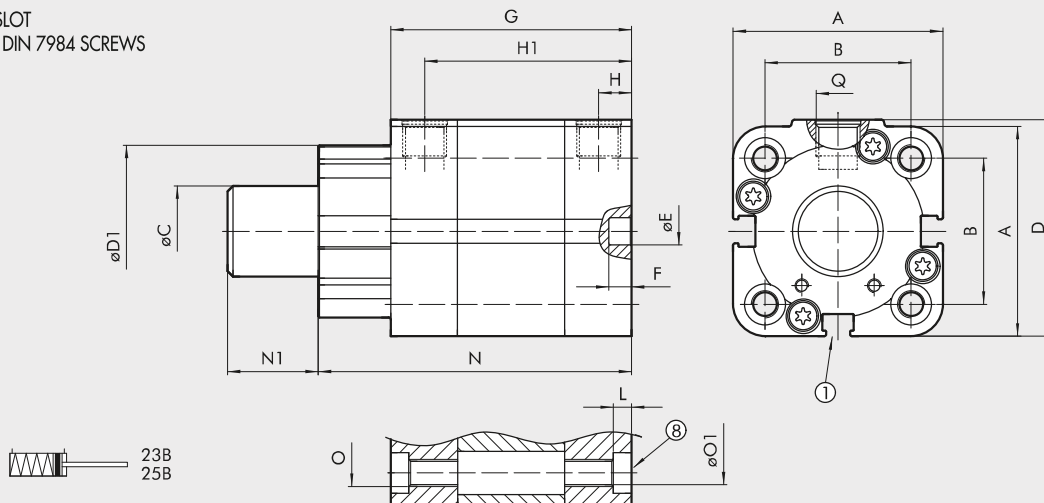

Ø	A	B		ØC	D	D1	ØE <sup>H9</sup>	F	G	H	H1	L	N	N1	O		ØO1		Q
		ISO	UNITOP												ISO	UNITOP			
32x20	47	32.5 <sup>+0.1</sup> <sub>-0.4</sub>	32 <sup>+0.4</sup> <sub>-0.1</sub>	20	48.5	38	6	4	64.5	7.5	57	4	80.5	20	M6	M6	5.2	5.2	G1/8
50x30	67	46.5	50	32	69	53	6	4	75.5	7.5	68	4.5	99.5	30	M8	M8	6.2	6.2	G1/8

Code	Description
23B0320020XP	Compact stopper cylinder, trunnion Ø 32, stroke 20 UNITOP
25B0320020XP	Compact stopper cylinder, trunnion Ø 32, stroke 20 ISO 15552
23B5320020XP	Compact stopper cylinder, trunnion Ø 32, stroke 20 UNITOP (non-magnetic version)
25B5320020XP	Compact stopper cylinder, trunnion Ø 32, stroke 20 ISO 15552 (non-magnetic version)
23B0500030XP	Compact stopper cylinder, trunnion Ø 50, stroke 30 UNITOP
25B0500030XP	Compact stopper cylinder, trunnion Ø 50, stroke 30 ISO 15552
23B5500030XP	Compact stopper cylinder, trunnion Ø 50, stroke 30 UNITOP (non-magnetic version)
25B5500030XP	Compact stopper cylinder, trunnion Ø 50, stroke 30 ISO 15552 (non-magnetic version)

**Ø 20 STROKE 15 mm ROLLER VERSION**

1 = SENSOR SLOT

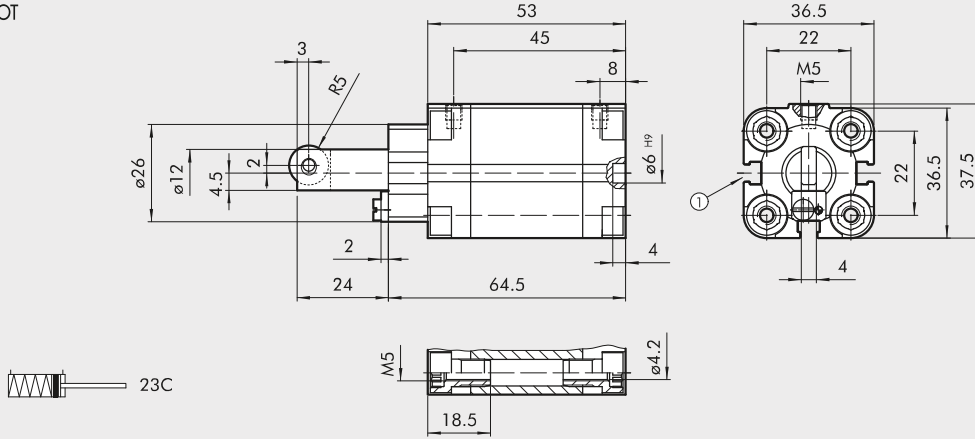

Code	Description
23C0200015XP	Compact stopper cylinder, roller Ø 20, stroke 15
23CS200015XP	Compact stopper cylinder, roller Ø 20, stroke 15 (non-magnetic version)

**Ø 32 STROKE 20 mm; Ø 50 STROKE 30 mm; Ø 80 STROKE 30 AND 40 mm ROLLER VERSION**

1 = SENSOR SLOT  
 7 = ONLY FOR Ø 80  
 8 = SEAT FOR DIN 7984 SCREWS

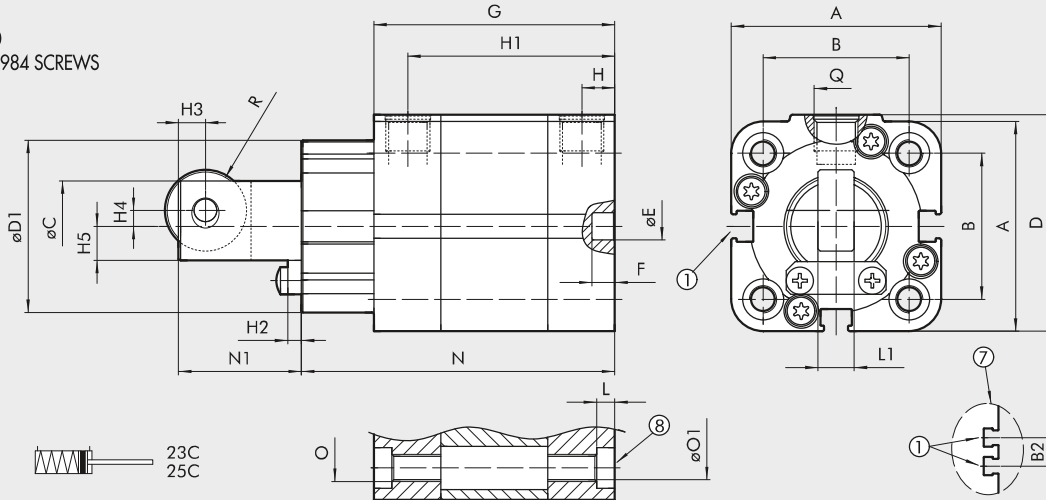

Ø	A	ISO	B		ØC	D	D1	ØE <sup>H9</sup>	G	F	H	H1	H2	H3	H4	H5	O		ØO1		L	L1	N	N1	Q	R
			UNITOP	B2													ISO	UNITOP								
32x20	47	32.5 <sup>+0.1</sup> <sub>-0.4</sub>	32 <sup>+0.1</sup> <sub>-0.1</sub>	-	20	48.5	38	6	64.5	4	7.5	57	3	6	3.5	7.5	M6	M6	5.2	5.2	4	8	80.5	38	G1/8	9
50x30	67	46.5	50	-	32	69	53	6	75.5	4	7.5	68	4	6	7	12	M8	M8	6.2	6.2	4.5	10	99.5	50.5	G1/8	12.5
80x30	102	72	82	17	50	105	76	8	126	4	8.5	117.5	8	10	11	18	M10	M10	8.5	8.5	5.5	18	141	63	G1/8	18
80x40	102	72	82	17	50	105	76	8	136	4	8.5	127.5	8	10	11	18	M10	M10	8.5	8.5	5.5	18	151	73	G1/8	18

Code	Description
23C0320020XP	Compact stopper cylinder, roller Ø 32, stroke 20 UNITOP
25C0320020XP	Compact stopper cylinder, roller Ø 32, stroke 20 ISO 15552
23CS320020XP	Compact stopper cylinder, roller Ø 32, stroke 20 UNITOP (non-magnetic version)
25CS320020XP	Compact stopper cylinder, roller Ø 32, stroke 20 ISO 15552 (non-magnetic version)
23C0500030XP	Compact stopper cylinder, roller Ø 50, stroke 30 UNITOP
25C0500030XP	Compact stopper cylinder, roller Ø 50, stroke 30 ISO 15552
23CS500030XP	Compact stopper cylinder, roller Ø 50, stroke 30 UNITOP (non-magnetic version)
25CS500030XP	Compact stopper cylinder, roller Ø 50, stroke 30 ISO 15552 (non-magnetic version)
23C0800030XP	Compact stopper cylinder, roller Ø 80, stroke 30 UNITOP
25C0800030XP	Compact stopper cylinder, roller Ø 80, stroke 30 ISO 15552
23CS800030XP	Compact stopper cylinder, roller Ø 80, stroke 30 UNITOP (non-magnetic version)
25CS800030XP	Compact stopper cylinder, roller Ø 80, stroke 30 ISO 15552 (non-magnetic version)
23C0800040XP	Compact stopper cylinder, roller Ø 80, stroke 40 UNITOP
25C0800040XP	Compact stopper cylinder, roller Ø 80, stroke 40 ISO 15552
23CS800040XP	Compact stopper cylinder, roller Ø 80, stroke 40 UNITOP (non-magnetic version)
25CS800040XP	Compact stopper cylinder, roller Ø 80, stroke 40 ISO 15552 (non-magnetic version)

## ACCESSORIES FOR STOPPER CYLINDER

### FLANGE Ø 32, Ø 50, Ø 80

+ = ADD THE STROKE

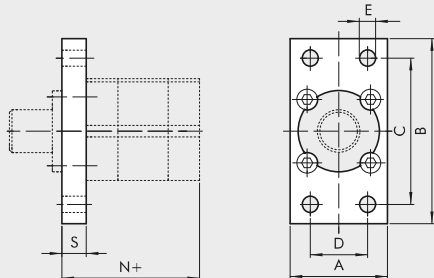

#### UNITOP

Code	Ø	A	B	C	D	E	N	S	Weight [g]
W0950326302	32	50	80	64	32	7	54.5	10	210
W0950506302	50	68	110	90	45	9	57.5	12	502
W0950806302	80	107	160	135	63	12	111	15	1575

#### ISO

Code	Ø	A	B	C	D	E	N	S	Weight [g]
W0950326302	32	50	80	64	32	7	54.5	10	210
W0950506312	50	65	110	90	45	9	57.5	12	447
W0950806312	80	95	153	126	63	12	112	16	1190

Note: Supplied with 4 screws.

## ACCESSORIES FOR COMPACT AND COMPACT TWO-FLAT CYLINDERS

### FOOT - MODEL A

+ = ADD THE STROKE

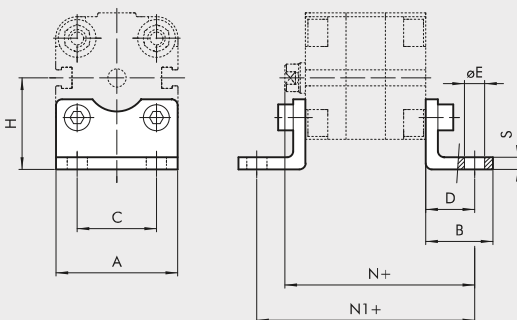

#### CMPC UNITOP, TWO-FLAT UNITOP

Code	Ø	A	B	C	D	ØE	H	N	N1	S	Weight [g]
W0950126001 ▲	12	30	17.5	18	13	5.5	22	55.5	64	3	26
W0950126001 ▲	16	30	17.5	18	13	5.5	22	55.5	64	3	26
W0950206001	20	36	22	22	16	6.6	27	58.5	70	4	46
W0950256001	25	40	22	26	16	6.6	30	58.5	71.5	4	52
W0950322001	32	45	35	32	24	7	31.9	74.5	92.5	4	76
W0950406001	40	60	28	42	20	9	42.5	72	85.5	5	88
W0950406001F *	40	60	28	42	20	9	42.5	72	85.5	5	88
W0950506001	50	68	32	50	24	9	47	77	93.5	6	176
W0950506001F *	50	68	32	50	24	9	47	77	93.5	6	176
W0950636001	63	84	39	62	27	11	59.5	84.5	104	6	276
W0950636001F *	63	84	39	62	27	11	59.5	84.5	104	6	276
W0950806001	80	102	42	82	30	11	65.5	94	116	8	392
W0951006001	100	123	45	103	33	13.5	78	109.5	132.5	8	558

\* Only for Two-Flat version

#### CMPC ISO, TWO-FLAT ISO

Code	Ø	A	B	C	D	ØE	H	N	N1	S	Weight [g]
W0950322001	32	45	35	32	24	7	31.9	74.5	92.5	4	76
W0950402001	40	52	43	36	28	9	36	80	101.5	4	100
W0950502001	50	65	47	45	32	9	45	85	109.5	4	162
W0950632001	63	75	47	50	32	9	50	89.5	114	6	266
W0950802001	80	95	61	63	41	12	63	105	138	6	456
W0951002001	100	115	65	75	41	14	71	117.5	148.5	6	572

Note: Individually packed with 2 screws.

▲ Non UNITOP norm fixing distance

### MALE HINGE-MODEL BA

+ = ADD THE STROKE

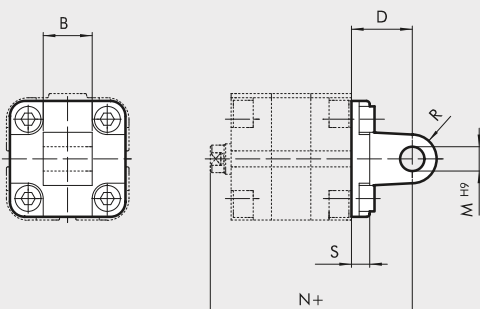

#### CMPC UNITOP, TWO-FLAT UNITOP

Code	Ø	B	D	M	N	R	S	Weight [g]
W0950126004 ▲	12	12	16	6	58.5	6	6	24
W0950126004 ▲	16	12	16	6	58.5	6	6	24
W0950206004	20	16	20	8	62.5	8	8	44
W0950256004	25	16	20	8	62.5	8	8	48

#### CMPC ISO, TWO-FLAT ISO

Code	Ø	B	D	M	N	R	S	Weight [g]
W0950322004	32	26	22	10	72.5	11	10	94
W0950402004	40	28	25	12	77	13	10	124
W0950502004	50	32	27	12	80	13	12	220
W0950632004	63	40	32	16	89.5	17	12	316
W0950802004	80	50	36	16	100	17	16	578
W0951002004	100	60	41	20	117.5	21	16	850

Note: Supplied with 4 screws, 4 washers

▲ Non UNITOP norm fixing distance