

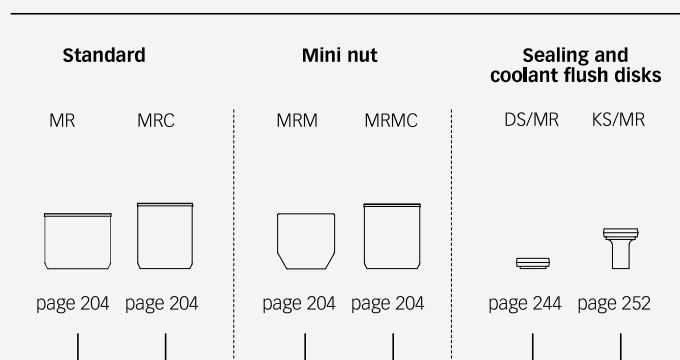

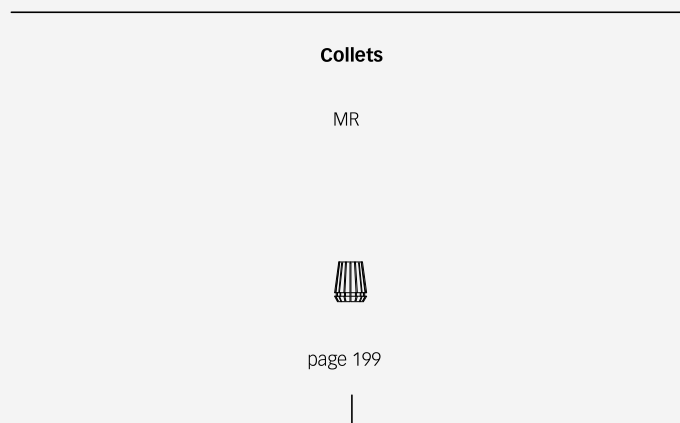

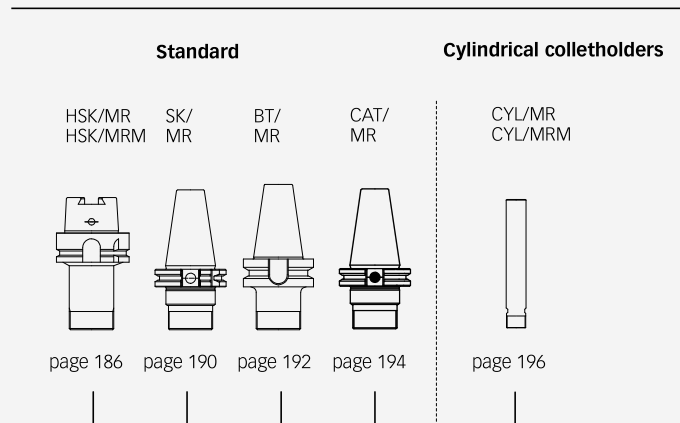

# Experience high-precision toolholding



Standard				Cylindrical colletholders
HSK/MR HSK/MRM	SK/ MR	BT/ MR	CAT/ MR	CYL/MR CYL/MRM
				
page 186	page 190	page 192	page 194	page 196



# Toolholders in Swiss quality



	<b>HSK/MR</b>	<b>BT/MR</b>	<b>SK/MR</b>	<b>CAT/MR</b>	<b>CYL/MR</b>	<b>CYL/MRM</b>
Norm	DIN 69893 ISO 12164	MAS 403 JIS B 6339 DIN-ISO 7388-2	DIN 69871 DIN ISO 7388-1	DIN 6871 DIN ISO 7388-1	–	–
Balancing	G 2.5 @ 25,000 min <sup>-1</sup>	G 2.5 @ 25,000 min <sup>-1</sup>	G 2.5 @ 25,000 min <sup>-1</sup>	G 2.5 @ 25,000 min <sup>-1</sup>	–	–
Chip hole	•	–	•	–	–	–
Runout TIR	≤0.003 mm	≤0.003 mm	≤0.003 mm	≤0.003 mm	≤0.003 mm	≤0.003 mm
Taper accuracy	DIN ISO	AT3	AT3	AT3	–	–
Form A + AD	–	•	•	–	–	–
Form AD + B	–	•	•	–	–	–
Shank tolerance	–	–	–	–	h6	h6

# HSK toolholders

Designed for rotating applications, all our HSK toolholders are suited for high-speed applications where a consistent performance is key.

DIN 69893 / ISO 12164

## Features and benefits

### Total system runout TIR $\leq 3 \mu\text{m}$ @ 3xD

Our holistic system consists of an micRun® toolholder, collet and clamping nut. All components together ensure best runout and accuracy.

### Toolholder runout TIR $\leq 1 \mu\text{m}$

Measured from inner taper to outer taper.

### Surface finish max. Ra 0.25

Achieve high clamping force and high transferable torque.

### Balancing

100% balanced to G 2.5 @ 25,000 rpm / <1gmm.

### MR clamping nut included in delivery

Guarantees highest clamping force and best balancing.

### Vibration dampening

Our holders offer good vibration dampening to sustain a high surface finish and can help prevent chatter.

*Accessories are not included in delivery*

### Expert advice

For all HSK-A and HSK-E form toolholders a range of coolant tubes (KSR) is available.

For KSR part numbers please refer to page 265.

### Balancing specifications

HSK 25	balanced to 90,000 min <sup>-1</sup>
HSK 32	balanced to 60,000 min <sup>-1</sup>
HSK 40	balanced to 45,000 min <sup>-1</sup>
HSK 50	balanced to 36,000 min <sup>-1</sup>
HSK 63	G 2.5 @ 25,000 min <sup>-1</sup>
HSK 80	G 2.5 @ 25,000 min <sup>-1</sup>
HSK 100	G 2.5 @ 25,000 min <sup>-1</sup>
HSK 125	G 2.5 @ 25,000 min <sup>-1</sup>



# HSK-A toolholders

HSK-A

DIN 69893

ISO 12164

Type	Part no.	Dimensions [mm]		Accessory
		D	L	Freewheel wrench head
<b>HSK-A 32</b>				
HSK-A 32/MRM 16 x 060	5532.11620	24	60	A-FLS Ø 24/MRM 16
HSK-A 32/MRM 16 x 100	5532.11650	24	100	A-FLS Ø 24/MRM 16
<b>HSK-A 40</b>				
HSK-A 40/MR 16 x 060	5540.11620	28	60	A-FLS Ø 28/MR 16
HSK-A 40/MR 16 x 100	5540.11650	28	100	A-FLS Ø 28/MR 16
HSK-A 40/MR 25 x 080	5540.12540	40	80	A-FLS Ø 40/MR 25
<b>HSK-A 50</b>				
HSK-A 50/MR 16 x 100	5550.11650	28	100	A-FLS Ø 28/MR 16
HSK-A 50/MR 25 x 080	5550.12540	40	80	A-FLS Ø 40/MR 25
<b>HSK-A 63</b>				
HSK-A 63/MR 11 x 100	5563.11150	16	100	A-FLS Ø 16/MR 11
HSK-A 63/MR 11 x 160	5563.11180	16	160	A-FLS Ø 16/MR 11
HSK-A 63/MR 16 x 100	5563.11650	28	100	A-FLS Ø 28/MR 16
HSK-A 63/MRM 16 x 100	5563.11657	24	100	A-FLS Ø 28/MR 16
HSK-A 63/MRM 16 x 160	5563.11687	24	160	A-FLS Ø 28/MR 16
HSK-A 63/MR 25 x 080	5563.12540	40	80	A-FLS Ø 40/MR 25
HSK-A 63/MR 25 x 160	5563.12580	40	160	A-FLS Ø 40/MR 25
HSK-A 63/MR 32 x 070	5563.13230	50	70	A-FLS Ø 50/MR 32
HSK-A 63/MR 32 x 100	5563.13250	50	100	A-FLS Ø 50/MR 32

Included in delivery: MR toolholders come with Hi-Q®/MR clamping nut  
 HSK-A: Hole for data carrier DIN STD 69873 in the flange available on request

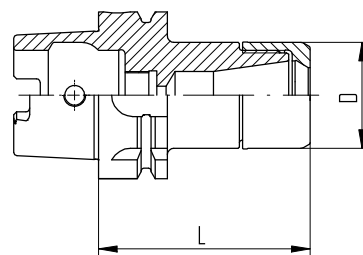

# HSK-E toolholders

HSK-E

DIN 69893

ISO 12164

Type	Part no.	Dimensions [mm]		Accessory
		D	L	Freewheel wrench head
<b>HSK-E 25</b>				
HSK-E 25/MR 11 x 045	5525.11114	16	45	A-FLS Ø 16/MR 11
HSK-E 25/MRM 16 x 045	5525.11618	24	45	A-FLS Ø 24/MRM 16
<b>HSK-E 32</b>				
HSK-E 32/MR 11 x 060	5532.11124	16	60	A-FLS Ø 16/MR 11
HSK-E 32/MRM 16 x 055	5532.11618	24	55	A-FLS Ø 24/MRM 16
<b>HSK-E 40</b>				
HSK-E 40/MR 11 x 050	5540.11114	16	50	A-FLS Ø 16/MR 11
HSK-E 40/MR 11 x 100	5540.11154	16	100	A-FLS Ø 16/MR 11
HSK-E 40/MRM 16 x 055	5540.11618	24	55	A-FLS Ø 24/MRM 16
HSK-E 40/MRM 16 x 080	5540.11648	24	80	A-FLS Ø 24/MRM 16
HSK-E 40/MR 25 x 065	5540.12520	40	65	A-FLS Ø 40/MR 25
<b>HSK-E 50</b>				
HSK-E 50/MR 16 x 100	5550.11654	28	100	A-FLS Ø 28/MR 16
HSK-E 50/MR 25 x 070	5550.12534	40	70	A-FLS Ø 40/MR 25

Included in delivery: MR toolholders come with Hi-Q®/MR clamping nut

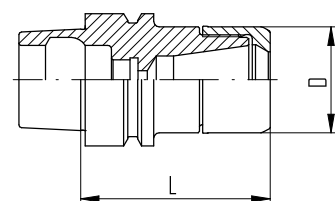

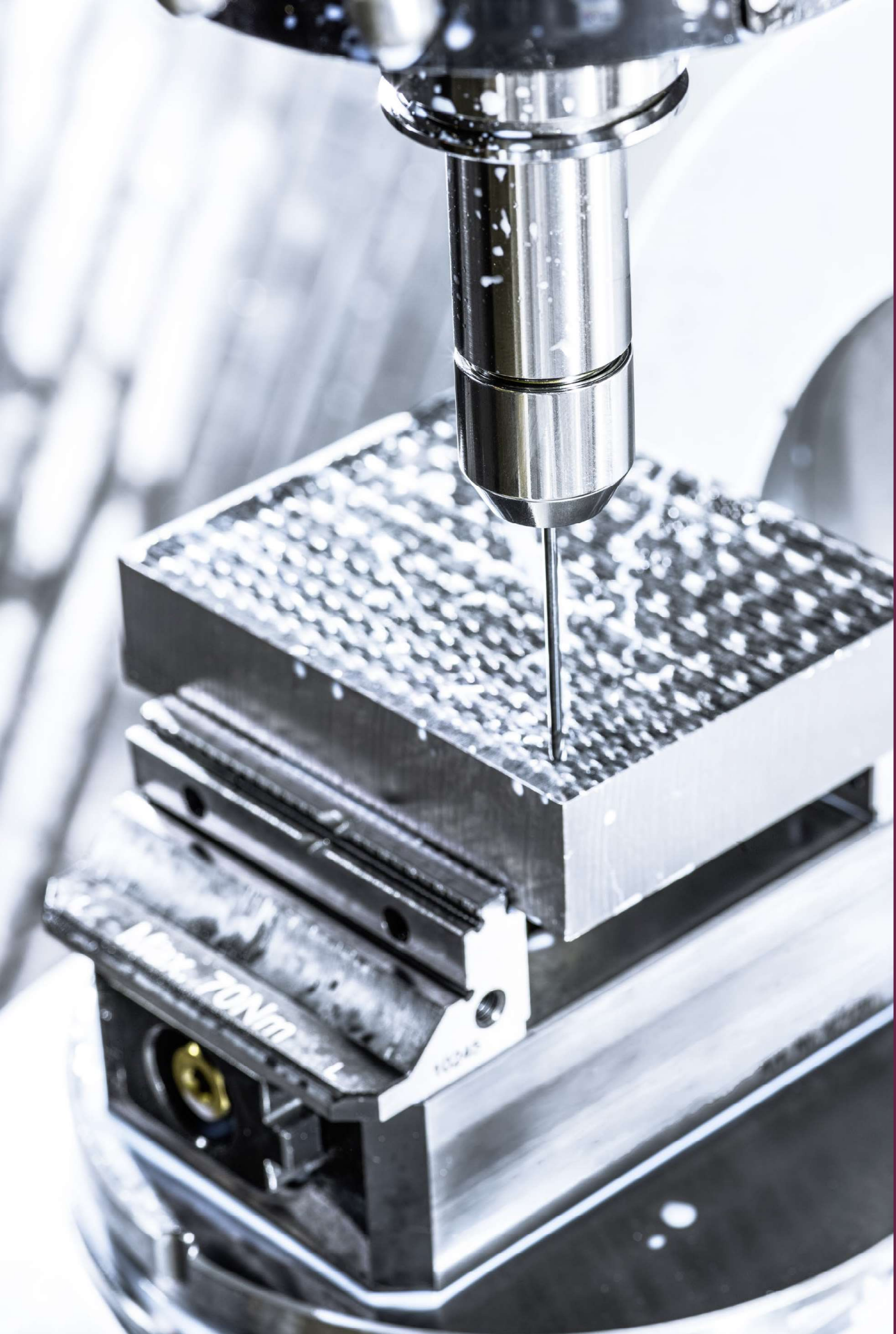



# Steep taper toolholders SK

Universally suitable for different machining applications.

DIN 69871 / DIN ISO 7388-1

## Features and benefits

### Total system runout TIR $\leq 3 \mu\text{m}$ @ 3xD

Our holistic system consists of an micRun® toolholder, collet and clamping nut. All components together ensure best runout and accuracy.

### Toolholder runout TIR $\leq 1 \mu\text{m}$

Measured from inner taper to outer taper.

### Taper accuracy AT3

Better spindle-to-holder fit and accuracy.

### Surface finish max. Ra 0.25

Achieve high clamping force and high transferable torque.

### Balancing

100% balanced to G 2.5 @ 25,000 rpm / <1gmm.

### MR clamping nut included in delivery

Guarantees highest clamping force and best balancing.

### Vibration dampening

Our holders offer good vibration dampening to sustain a high surface finish and can help prevent chatter.

*Accessories are not included in delivery*

### Balancing specifications

SK 30	balanced to 30,000 min <sup>-1</sup>
SK 40	G 2.5 @ 25,000 min <sup>-1</sup>
SK 50	G 2.5 @ 25,000 min <sup>-1</sup>



Type	Part no.	Dimensions [mm]		Accessory
		D	L	Freewheel wrench head
<b>SK 30</b>				
SK 30/MR 16 x 050	5230.11610	28	50	A-FLS Ø 28/MR 16
SK 30/MR 16 x 100	5230.11650	28	100	A-FLS Ø 28/MR 16
SK 30/MR 25 x 070	5230.12530	40	70	A-FLS Ø 40/MR 25
<b>SK 40</b>				
SK 40/MR 11 x 100	5240.11150	16	100	A-FLS Ø 16/MR 11
SK 40/MR 16 x 070	5240.11630	28	70	A-FLS Ø 28/MR 16
SK 40/MR 16 x 100	5240.11650	28	100	A-FLS Ø 28/MR 16
SK 40/MR 16 x 160	5240.11680	28	160	A-FLS Ø 28/MR 16
SK 40/MR 25 x 070	5240.12530	40	70	A-FLS Ø 40/MR 25
SK 40/MR 25 x 100	5240.12550	40	100	A-FLS Ø 40/MR 25
SK 40/MR 25 x 160	5240.12580	40	160	A-FLS Ø 40/MR 25
SK 40/MR 32 x 070	5240.13230	50	70	A-FLS Ø 50/MR 32
SK 40/MR 32 x 100	5240.13250	50	100	A-FLS Ø 50/MR 32
SK 40/MR 32 x 160	5240.13280	50	160	A-FLS Ø 50/MR 32

Included in delivery: MR toolholders come with Hi-Q®/MR clamping nut

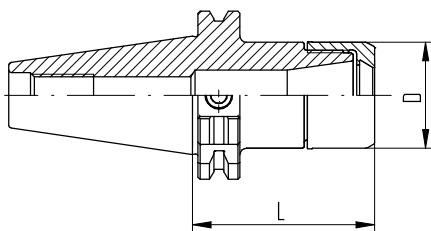

SK / MR (Form A+AD)

### Expert advice

We recommend tightening the clamping nuts with our TORCO-BLOCK or torque wrench. Get the best accuracy by respecting the suitable tightening forces.

# Steep taper toolholders BT

Universally suitable different machining applications, the BT interface toolholders cater to different machining needs.

MAS 403 / JIS B 6339 / DIN ISO 7388-2

## Features and benefits

### Total system runout TIR $\leq 3 \mu\text{m}$ @ 3xD

Our holistic system consists of an micRun® toolholder, collet and clamping nut. All components together ensure best runout and accuracy.

### Toolholder runout TIR $\leq 1 \mu\text{m}$

Measured from inner taper to outer taper.

### Taper accuracy AT3

Better spindle-to-holder fit and accuracy.

### Surface finish max. Ra 0.25

Achieve high clamping force and high transferable torque.

### Balancing

100% balanced to G 2.5 @ 25,000 rpm / <1gmm.

### MR clamping nut included in delivery

Guarantees highest clamping force and best balancing.

### Vibration dampening

Our holders offer good vibration dampening to sustain a high surface finish and can help prevent chatter.

*Accessories are not included in delivery*

## Balancing specifications

BT 30	balanced to 30,000 min <sup>-1</sup>
BT 40	G 2.5 @ 25,000 min <sup>-1</sup>



# BT toolholders

BT

MAS 403

JIS B 6339

DIN ISO 7388-2

Type	Part no.	Dimensions [mm]		Accessory
		D	L	Freewheel wrench head
<b>BT 30</b>				
BT 30/MR 11 x 050	5130.11110	16	50	A-FLS Ø 16/MR 11
BT 30/MR 11 x 100	5130.11150	16	100	A-FLS Ø 16/MR 11
BT 30/MR 16 x 050	5130.11610	28	50	A-FLS Ø 28/MR 16
BT 30/MR 16 x 080	5130.11640	28	80	A-FLS Ø 28/MR 16
BT 30/MR 16 x 100	5130.11650	28	100	A-FLS Ø 28/MR 16
BT 30/MR 25 x 060	5130.12520	40	60	A-FLS Ø 40/MR 25
BT 30/MR 25 x 100	5130.12550	40	100	A-FLS Ø 40/MR 25
BT 30/MR 32 x 060	5130.13220	50	60	A-FLS Ø 50/MR 32
<b>BT 40</b>				
BT 40/MR 11 x 100	5140.11150	16	100	A-FLS Ø 16/MR 11
BT 40/MR 16 x 070	5140.11630	28	70	A-FLS Ø 28/MR 16
BT 40/MR 16 x 100	5140.11650	28	100	A-FLS Ø 28/MR 16
BT 40/MR 25 x 070	5140.12530	40	70	A-FLS Ø 40/MR 25
BT 40/MR 25 x 100	5140.12550	40	100	A-FLS Ø 40/MR 25
BT 40/MR 32 x 070	5140.13230	50	70	A-FLS Ø 50/MR 32
BT 40/MR 32 x 100	5140.13250	50	100	A-FLS Ø 50/MR 32

Included in delivery: MR toolholders come with Hi-Q®/MR clamping nut

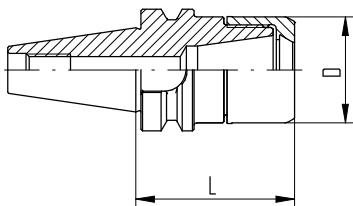

BT/MR (Form A+AD)

## Expert advice

We recommend tightening the clamping nuts with our TORCO-BLOCK or torque wrench.

# Steep taper toolholders CAT

Universally suitable for different machining applications.

ASME B5.50

## Features and benefits

### **Total system runout TIR $\leq 0.0001"$ (3 $\mu\text{m}$ )**

Our holistic system consists of an micRun® toolholder, collet and clamping nut. All components together ensure best runout and accuracy.

### **Toolholder runout TIR $\leq 1 \mu\text{m}$**

Measured from inner taper to outer taper.

### **Taper accuracy AT3**

Better spindle-to-holder fit and accuracy.

### **Surface finish max. Ra 0.25**

Achieve high clamping force and high transferable torque.

### **Balancing**

100% balanced to G 2.5 @ 22,000 rpm.

### **MR clamping nut included in delivery**

Guarantees highest clamping force and best balancing.

### **Vibration dampening**

Our holders offer good vibration dampening to sustain a high surface finish and can help prevent chatter.

*Accessories are not included in delivery*



# CAT toolholders

**CAT**  
ASME B5.50

Type	Part no.	Dimensions [mm]		Accessory
		D	L	Freewheel wrench head
<b>CAT 40*</b>				
CAT 40/MR 16 x 3"	5340.11631	28	3"	A-FLS Ø 28/MR 16
CAT 40/MR 16 x 6"	5340.11671	28	6"	A-FLS Ø 28/MR 16
CAT 40/MR 32 x 3"	5340.13231	50	3"	A-FLS Ø 50/MR 32

\*USA only

Included in delivery: MR toolholders come with Hi-Q®/MR clamping nut

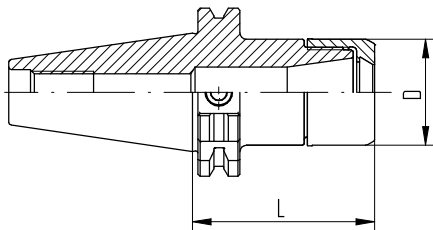

CAT / MR (form A+AD)

# Cylindrical shank toolholders CYL

CYL

## Features and benefits

### Total system runout TIR $\leq 3 \mu\text{m}$ @ 3xD

Our holistic system consists of an micRun® toolholder, collet and clamping nut. All components together ensure best runout and accuracy.

### Toolholder runout TIR $\leq 1 \mu\text{m}$

Measured from inner taper to cylindrical shank.

### Surface finish max. Ra 0.25

Achieve high clamping force and high transferable torque.

### Sizes

CYL/MR 11 and CYL/MRM 16

### Application

CYL/MR is suited for Swiss automatic machines, machining centers and conventional machines.

### MR clamping nut included in delivery

Guarantees maximum precision combined with slimmest diameter.

### Vibration dampening

Our holders offer good vibration dampening to sustain a high surface finish and can help prevent chatter.

*Accessories are not included in delivery*

### Expert advice

We recommend tightening the clamping nuts using a torque wrench. Get the best accuracy by respecting the suitable tightening forces.

*For tightening torque recommendations, please refer to page 293.*



Type	Part no.	Dimensions [mm]				G	Accessory
		D	L	L1	L2		Freewheel wrench head
<b>CYL 16</b>							
CYL 16 x 150/MR 11	5616.11190	16	150	17.2	20	M 8 x 1	A-FLS Ø 16/MR 11
CYL 16 x 200/MR 11	5616.11100	16	200	17.2	20	M 8 x 1	A-FLS Ø 16/MR 11
<b>CYL 20</b>							
CYL 20 x 150/MRM 16	5620.21690	24	150	25.2	25	M 12 x 1	A-FLS Ø 24/MRM 16
CYL 20 x 200/MRM 16	5620.21600	24	200	25.2	25	M 12 x 1	A-FLS Ø 24/MRM 16

*Included in delivery: MR toolholders come with HI-Q®/MR clamping nut*

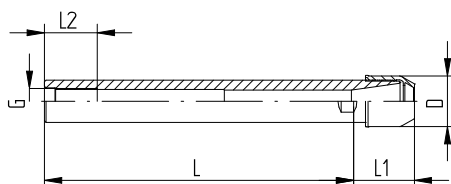

CYL/MR





---

Collets

MR



page 199

---

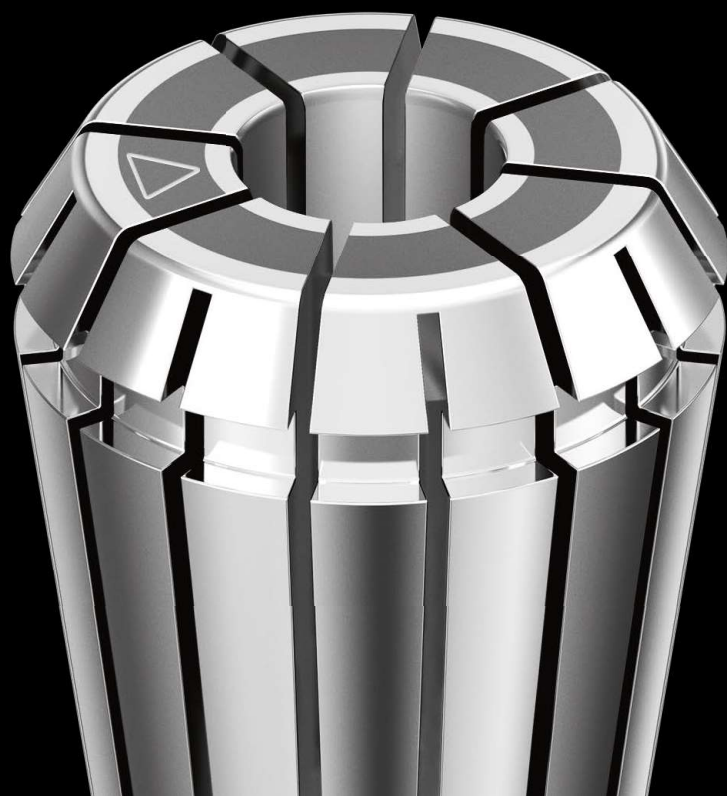

# Swiss quality MR collets

Type	Part no.	Ø		max. Shank tolerance
		[mm]	[inch]	
<b>MR 11 [mm]</b>				
Ø 1.0 mm	1111.01006	1.0	–	h11
Ø 2.0 mm	1111.02006	2.0	–	h11
Ø 3.0 mm	1111.03006	3.0	–	h11
Ø 4.0 mm	1111.04006	4.0	–	h11
Ø 5.0 mm	1111.05006	5.0	–	h11
Ø 6.0 mm	1111.06006	6.0	–	h11

<b>MR 11 [inch]</b>				
Ø 1/8"	1111.03186	3.175	1/8"	h11
Ø 3/16"	1111.04766	4.763	3/16"	h11
Ø 1/4"	1111.06356	6.35	1/4"	h11

<b>MR 16 [mm]</b>				
Ø 1.0 mm	1116.01006	1.0	–	h11
Ø 2.0 mm	1116.02006	2.0	–	h11
Ø 3.0 mm	1116.03006	3.0	–	h11
Ø 4.0 mm	1116.04006	4.0	–	h11
Ø 5.0 mm	1116.05006	5.0	–	h11
Ø 6.0 mm	1116.06006	6.0	–	h11
Ø 8.0 mm	1116.08006	8.0	–	h11
Ø 10.0 mm	1116.10006	10.0	–	h11





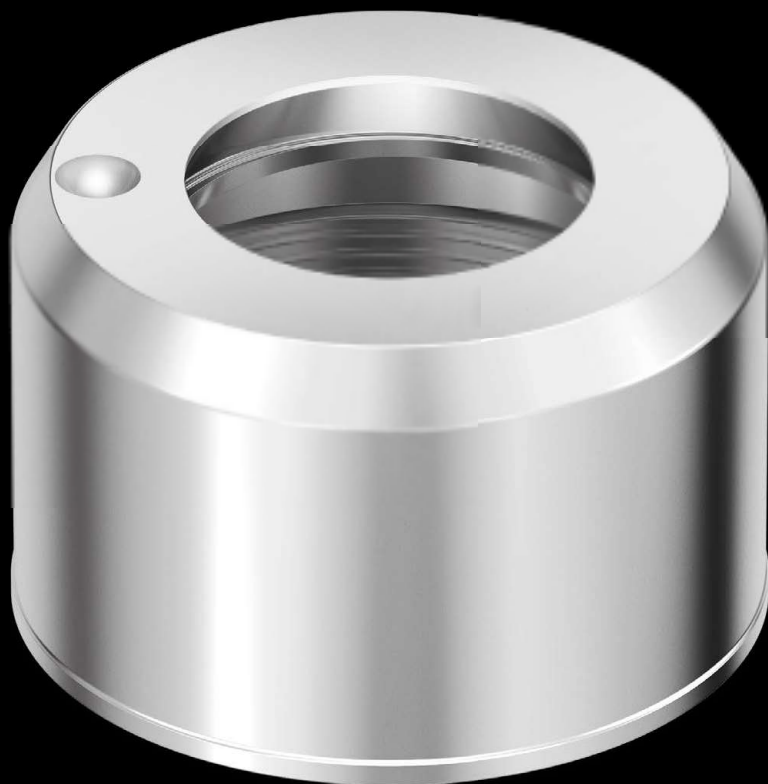

<b>MR 16 [inch]</b>				
Ø 1/8"	1116.03186	3.175	1/8"	h11
Ø 3/16"	1116.04766	4.763	3/16"	h11
Ø 1/4"	1116.06356	6.35	1/4"	h11
Ø 5/16"	1116.07946	7.938	5/16"	h11
Ø 3/8"	1116.09536	9.525	3/8"	h11

Type	Part no.	Ø [mm]	Ø [inch]	max. Shank tolerance
<b>MR 25 [mm]</b>				
Ø 1.0 mm	1125.01006	1.0	–	h11
Ø 2.0 mm	1125.02006	2.0	–	h11
Ø 3.0 mm	1125.03006	3.0	–	h11
Ø 4.0 mm	1125.04006	4.0	–	h11
Ø 5.0 mm	1125.05006	5.0	–	h11
Ø 6.0 mm	1125.06006	6.0	–	h11
Ø 8.0 mm	1125.08006	8.0	–	h11
Ø 10.0 mm	1125.10006	10.0	–	h11
Ø 12.0 mm	1125.12006	12.0	–	h11
Ø 14.0 mm	1125.14006	14.0	–	h11
Ø 16.0 mm	1125.16006	16.0	–	h11
<b>MR 25 [inch]</b>				
Ø 1/8"	1125.03186	3.175	1/8"	h11
Ø 1/4"	1125.06356	6.35	1/4"	h11
Ø 5/16"	1125.07946	7.938	5/16"	h11
Ø 3/8"	1125.09536	9.525	3/8"	h11
Ø 7/16"	1125.11116	11.113	7/16"	h11
Ø 1/2"	1125.12706	12.7	1/2"	h11
Ø 9/16"	1125.14296	14.288	9/16"	h11
Ø 5/8"	1125.15886	15.875	5/8"	h11
<b>MR 32 [mm]</b>				
Ø 2.0 mm	1132.02006	2.0	–	h11
Ø 3.0 mm	1132.03006	3.0	–	h11
Ø 4.0 mm	1132.04006	4.0	–	h11
Ø 5.0 mm	1132.05006	5.0	–	h11
Ø 6.0 mm	1132.06006	6.0	–	h11
Ø 8.0 mm	1132.08006	8.0	–	h11
Ø 10.0 mm	1132.10006	10.0	–	h11
Ø 12.0 mm	1132.12006	12.0	–	h11
Ø 14.0 mm	1132.14006	14.0	–	h11
Ø 16.0 mm	1132.16006	16.0	–	h11
Ø 18.0 mm	1132.18006	18.0	–	h11
Ø 20.0 mm	1132.20006	20.0	–	h11

Type	Part no.	Ø		max. Shank tolerance
		[mm]	[inch]	
<b>MR 32 [inch]</b>				
Ø 1/4"	1132.06356	6.35	1/4"	h11
Ø 5/16"	1132.07946	7.938	5/16"	h11
Ø 3/8"	1132.09536	9.525	3/8"	h11
Ø 7/16"	1132.11116	11.113	7/16"	h11
Ø 1/2"	1132.12706	12.7	1/2"	h11
Ø 9/16"	1132.14296	14.288	9/16"	h11
Ø 5/8"	1132.15886	15.875	5/8"	h11
Ø 11/16"	1132.17466	17.463	11/16"	h11
Ø 3/4"	1132.19056	19.05	3/4"	h11





Standard		Mini nut		Sealing and coolant flush disks	
MR	MRC	MRM	MRMC	DS/MR	KS/MR
					
page 204	page 204	page 204	page 204	page 244	page 252

*C: cooling M: mini thread DS: sealing disk KS: coolant flush disk*

# Grooveless MR nuts for high-end machining



	Hi-Q/MR	Hi-Q/MRC	Hi-Q/MRM	Hi-Q/MRMC
Main feature	Standard micRun® nut	micRun® nut for coolant through	micRun® mini nut	micRun® mini nut for coolant through
Sizes	MR 11/16/25/32	MR 11/16/25/32	MRM 16	MRM 16
Minimal outer diameter	–	–	•	•
Grooveless	•	•	•	•
Suitable wrench	A-FLS	A-FLS	A-FLS	A-FLS
Compatible with DS	–	•	–	•
Compatible with KS	–	•	–	•

#### Expert advice

Due to the thread, micRun® MR-clamping nuts are only compatible with MR-toolholders.

# MR Clamping nuts

## MRM Mini clamping nuts

## MRC and MRMC clamping nuts for coolant through tools (DS/KS)

Type	Part no.	Dimensions [mm]		
		A	B	L1
<b>MR 11</b>				
Hi-Q/MR 11	3611.00000	16	16.2	4.5
<b>MR 16</b>				
Hi-Q/MR 16	3616.00000	28	23.1	6.7
<b>MR 25</b>				
Hi-Q/MR 25	3625.00000	40	25.5	8.1
<b>MR 32</b>				
Hi-Q/MR 32	3632.00000	50	31.8	9.1

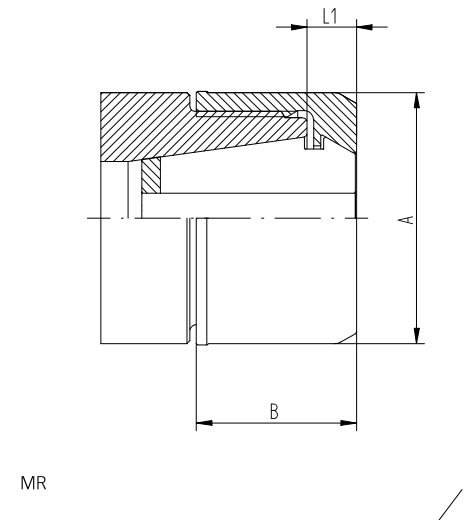

Type	Part no.	Dimensions [mm]		
		A	B	L1
<b>MRM 16</b>				
Hi-Q/MRM 16	3616.80000	24	23.1	6.7

Type	Part no.	Dimensions [mm]		
		A	B	L1
<b>MRC 16</b>				
Hi-Q/MRC 16	3616.20000	28	28.1	11.7
<b>MRC 25</b>				
Hi-Q/MRC 25	3625.20000	40	30.5	13.1
<b>MRC 32</b>				
Hi-Q/MRC 32	3632.20000	50	36.8	14.1

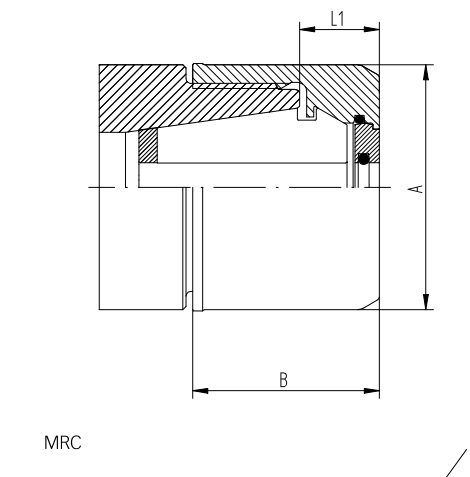

Type	Part no.	Dimensions [mm]		
		A	B	L1
<b>MRMC 16</b>				
Hi-Q/MRMC 16	3616.90000	24	28.1	11.7