

200W 3-Phase AC Gear Motor

GEAR-HV200

Buy 3-phase AC gear motor at good price. Rated power 200W, power supply 110V/220V/380V at 3-phase or single phase, optional gear ratio 3:1~100:1, output torque 0.31-11.5 kg.m, output shaft diameter 18mm/22mm/28mm, horizontal/vertical installation. Matched with brake to control speed better.

Basic Specification

Model	CH22-200-15-S
Rated Power	200W
Rated Voltage	Single-phase 110V, 50/60Hz Single-phase 220V, 50/60Hz 3-phase 220V, 50/60Hz 3-phase 380-415V, 50/60Hz
Gear Ratio	3:1/ 5:1/ 10:1/ 15:1/ 20:1/ 25:1/ 30:1/ 40:1/ 45:1/ 50:1/ 60:1/ 70:1/ 80:1/ 90:1/ 100:1
Duty	Continuous running
Working Environment	Temperature 10℃~+40℃ Humidity ≤90%
Pole	4P (6P)
Working Height	≤1000m
Standard	GB755/IEC-60034

200W AC Gear Motor Load Current Value

Phase	3-Phase							
Frequency	50Hz				60Hz			
Voltage	220V	380V	415V	440V	220V	380V	440V	460V
Current	1.15A	0.67A	0.70A	0.58A	1.10A	0.63A	0.55A	0.52A
Phase	Single-Phase							
Frequency	50Hz				60Hz			
Voltage	110V	115V	220V	230V	110V	115V	220V	230V
Current	3.00A	2.80A	1.50A	1.40A	2.50A	2.30A	1.25A	1.16A

200W AC Gear Motor Output Torque

Gear Ratio		3	5	10	15	20	25	30	40	45	50	60	70	80	90	100
Output Speed(rpm)	50Hz	465	300	150	100	75	60	50	37	33	30	25	21	19	17	15
	60Hz	570	360	180	120	90	72	60	45	40	36	30	25	23	20	18
Output Torque(kg.m)	50Hz	0.37	0.62	1.24	1.8	2.4	3	3.6	4.6	5.4	5.7	6.9	8	9.2	10.3	11.5
	60Hz	0.31	0.52	1.04	1.5	2	2.5	3	3.9	4.4	4.8	5.8	6.8	7.7	8.6	9.6

200W Horizontal AC Gear Motor Dimensions (Unit: mm)

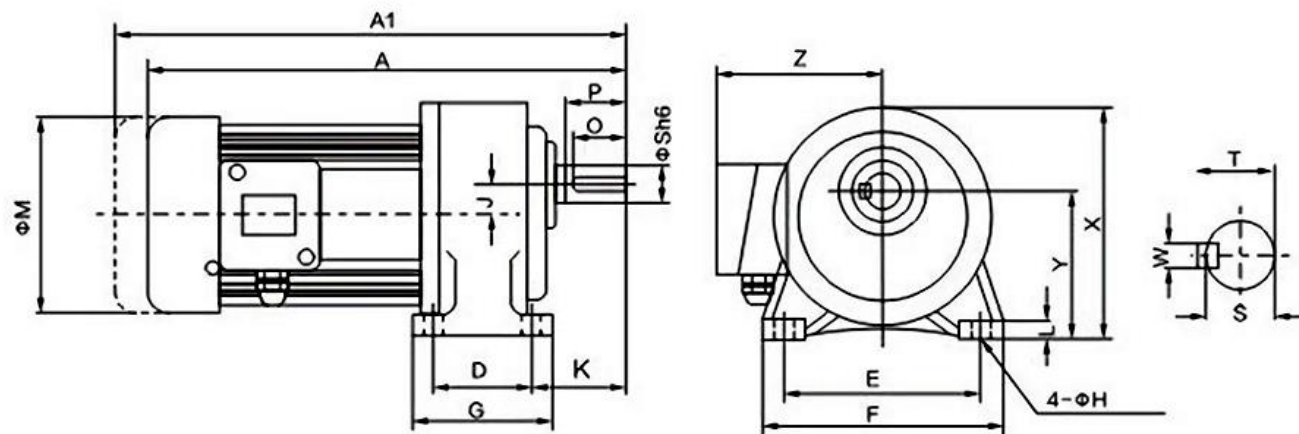

Gear Ratio	Shaft Diameter	A	D	E	F	G	H	J	K	L	M	X	Y	Z	S	P	Q	W	T	Weight (kg)
3~10	18	290	40	110	135	65	9	16	50	14	129	132	88.5	110	18	30	25	5	20	6.5
15~90	22	320	65	130	158	90	11	18.17	60	13	129	152	97.5	110	22	40	35	7	25	8
100~200	28	355	90	140	178	120	11	20.8	70	14	129	178	116	110	28	45	40	7	31	10.5

200W Vertical AC Gear Motor Dimensions (Unit: mm)

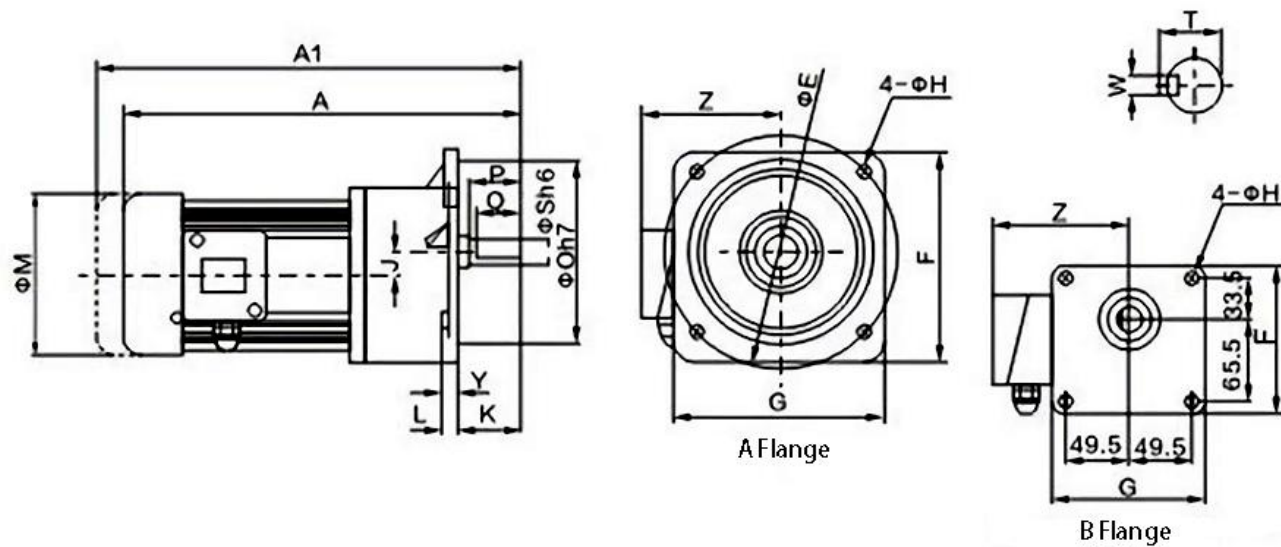

Gear Ratio	Shaft Diameter	A	D	E	F	G	H	J	K	L	M	Y	Z	S	P	Q	W	T	Weight (kg)
3~10	18 (B)	290	50	140	120	120	9	16	39	10	129	6	110	18	30	25	5	20	8
15~90	22	320	148	185	176	165	11	18.17	45	12	129	3.5	110	22	40	35	7	25	8.8
100~200	28	355	170	220	218	200	11	20.8	58	14	129	4	110	28	45	40	7	31	10.8