

Nema 23 Stepper Motor

Nema 23 hybrid bipolar stepper motor is a permanent magnet stepper motor with an end face size of 56mm x 56mm. Nema 23 stepper motor is simple structure, small size and easy assembly. High torque stepper motor at factory price, including 2 phase open loop, 3 phase open loop and 2 phase closed loop, can be controlled by AC or DC digital stepper drivers for precise position control.

2 Phase Open Loop Stepper Motor



Specification

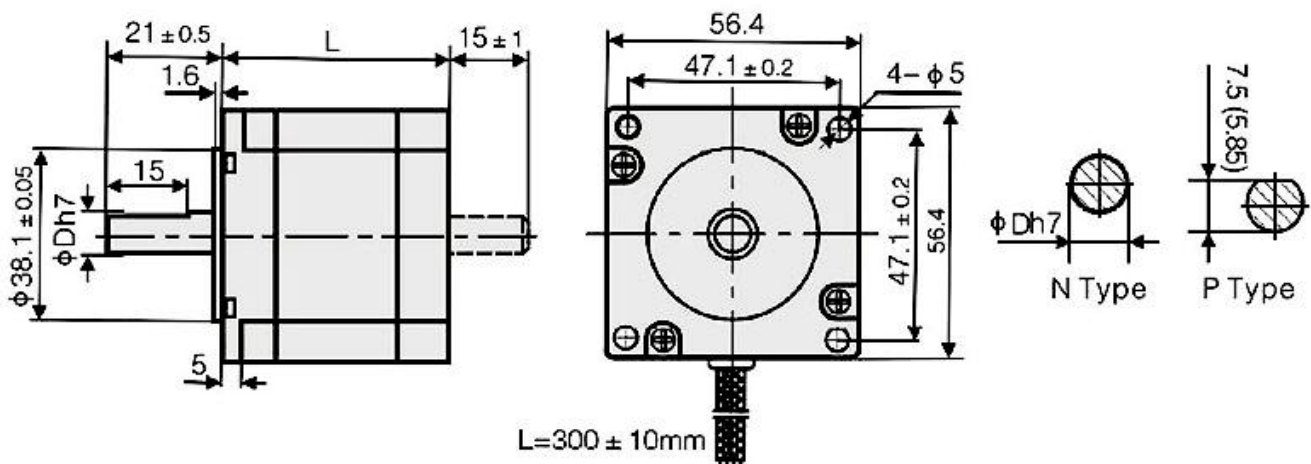

Model	Step Angle (°)	Motor Length (mm)	Rated Current (A)	Holding Torque (N.m)	Phase Resistance (Ω)	Phase Inductance (mH)	Rotor Inertia (g.cm ²)	Lead Wires (NO.)	Motor Weight (Kg)
FY56ES250A	1.8	41	4.2	0.40	1.4	1.4	150	4	0.47
FY56EC350A		82	3.5	2.20	0.9	3.0	520	4	1.20
FY56EL300A		76	3.0	1.00	1.0	3.5	460	4	1.00
FY56EM300A		54	3.0	1.00	0.9	5.2	260	4	0.70
FY56ED420A		100	4.2	3.00	0.7	2.9	680	4	1.50

Technical Specification	
Shaft Diameter	8mm/ 6.35mm
Step Angle Accuracy	±5% (Full Step, No Load)
Resistance Accuracy	± 10% (20°C)
Inductance Accuracy	±20% (1KHz)
Temperature Rise	80°C Max. (rated current, 2 phase on)
Ambient Temperature	-20°C~+50°C
Insulation Resistance	100MΩ Min. 500VDC
Dielectric Strength	1Min. 500VAC
Shaft Radial Play	0.02Max. 450g Load
Shaft Axial Play	0.08Max. 450g Load
Radial Max. Load	28N
Axial Max. Load	10N
Warranty Period	12 months
Certificate	CE, ROHs, FCC

Wiring Diagram

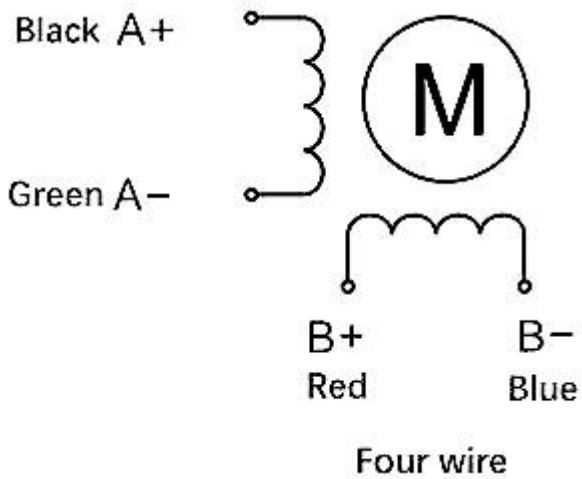

Speed-Torque Curve Diagram

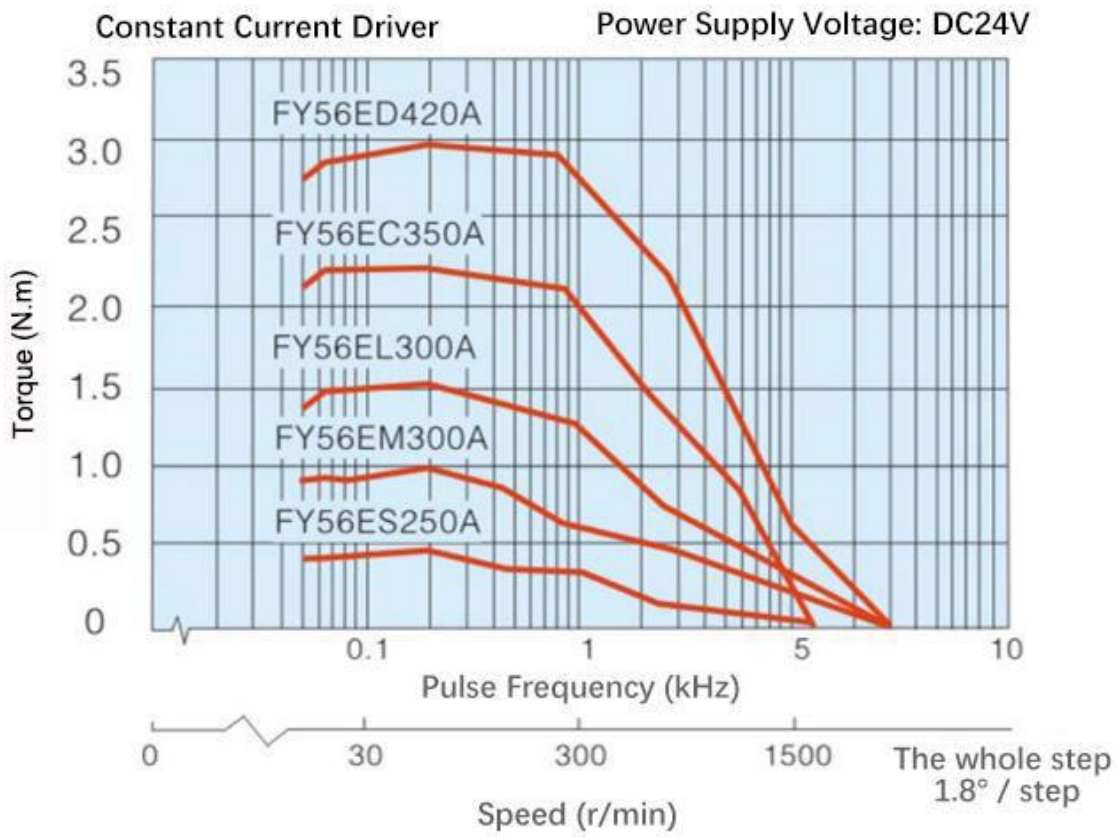

3 Phase Open Loop Stepper Motor



Specification

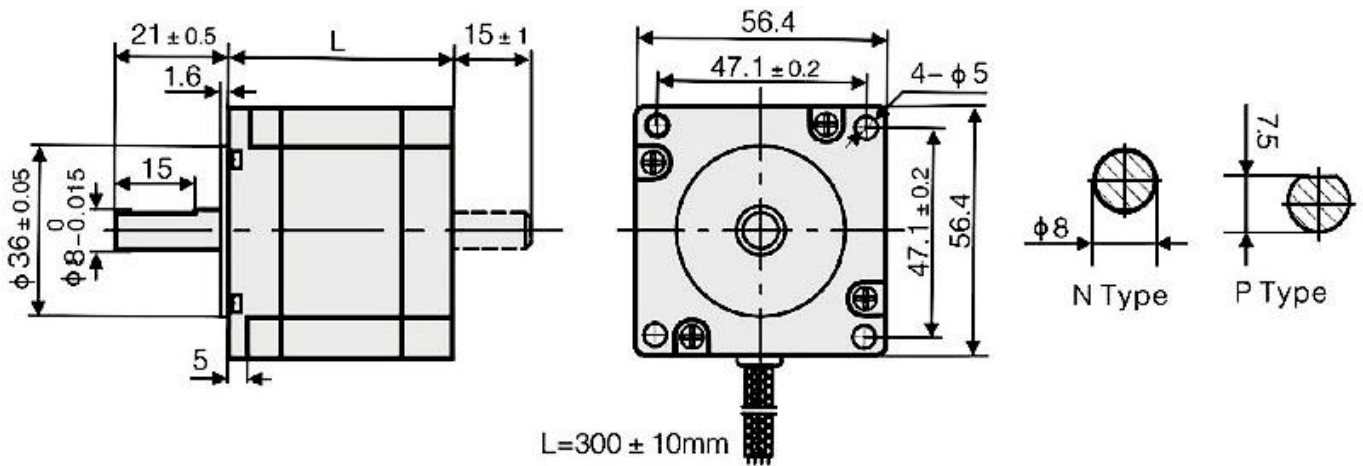

Model	Step Angle (°)	Motor Length (mm)	Rated Current (A)	Holding Torque (N.m)	Phase Resistance (Ω)	Phase Inductance (mH)	Rotor Inertia (g.cm ²)	Lead Wires (NO.)	Motor Weight (Kg)
FY56TM530A	1.8	54	5.3	0.90	0.35	1.1	300	3	0.70
FY56TL580A		76	5.8	1.50	0.55	1.7	480	3	1.00
FY56TC580A		106	5.8	2.50	0.57	1.2	720	3	1.80

Technical Specification	
Shaft Diameter	8mm
Step Angle Accuracy	±5% (Full Step, No Load)
Resistance Accuracy	± 10% (20°C)
Inductance Accuracy	±20% (1KHz)
Temperature Rise	80°C Max. (rated current, 2 phase on)
Ambient Temperature	-20°C~+50°C
Insulation Resistance	100MΩ Min. 500VDC
Dielectric Strength	1Min. 500VAC
Shaft Radial Play	0.02Max. 450g Load
Shaft Axial Play	0.08Max. 450g Load
Radial Max. Load	75N
Axial Max. Load	15N
Warranty Period	12 months
Certificate	CE, ROHs, FCC

Wiring Diagram

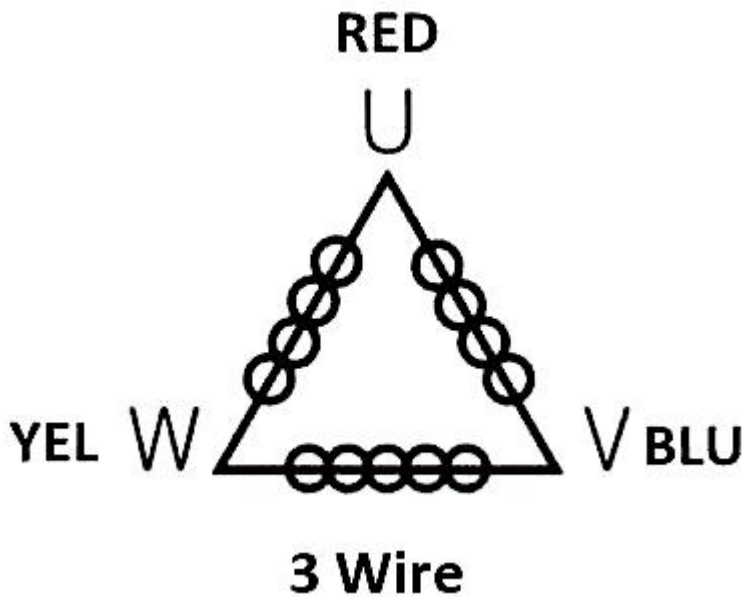

Speed-Torque Curve Diagram

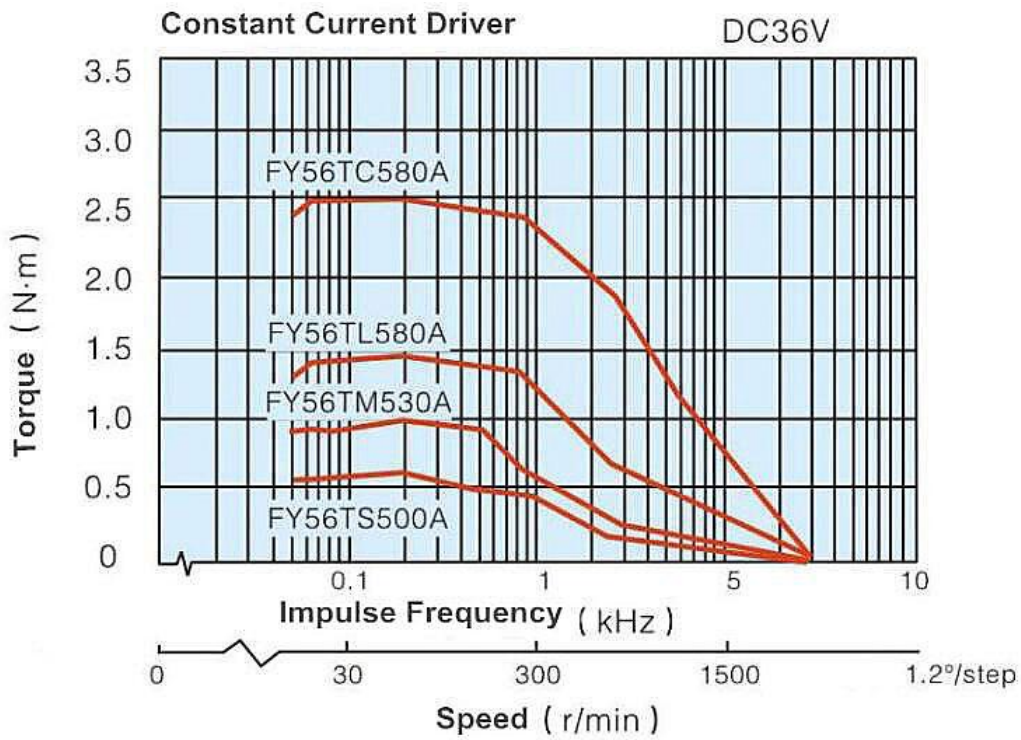

2 Phase Closed Loop Stepper Motor



Specification

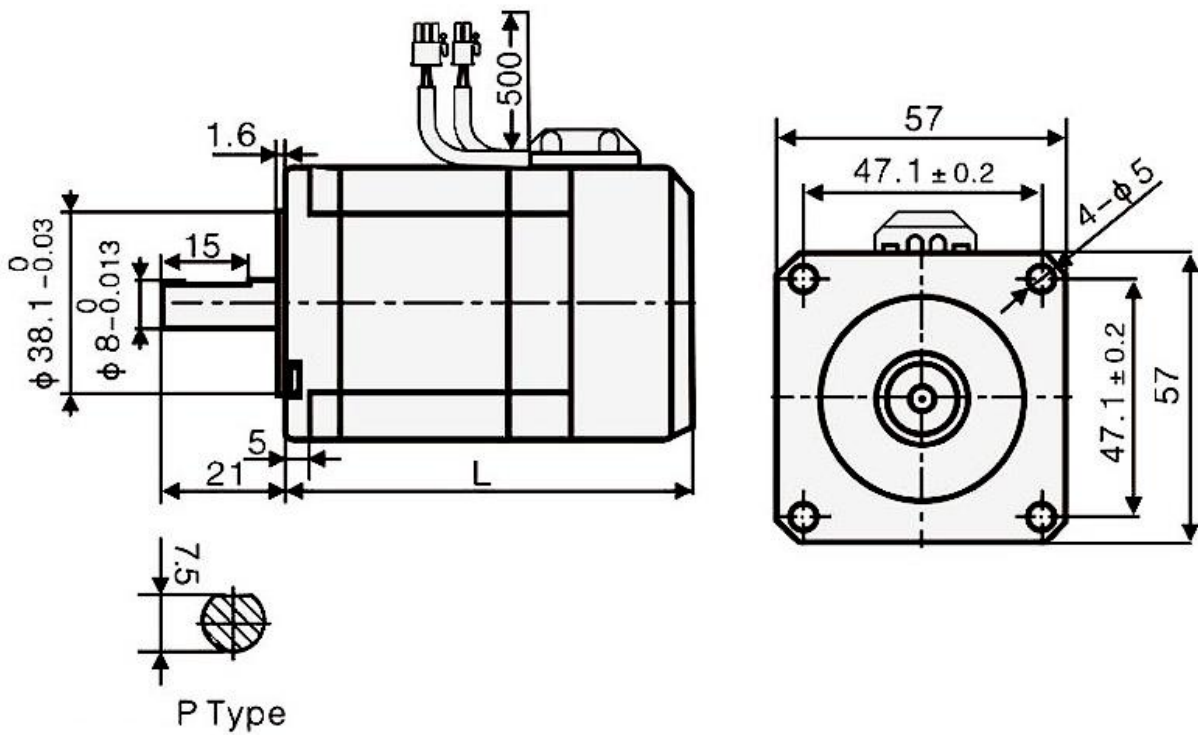

Model	Step Angle (°)	Motor Length (mm)	Rated Current (A)	Holding Torque (N.m)	Phase Resistance (Ω)	Phase Inductance (mH)	Rotor Inertia (g.cm ²)	Lead Wires (NO.)	Motor Weight (Kg)
FY56EM420BC1	1.8	76	4.2	1.20	0.44	1.4	280	4	1.00
FY56EC520BC1		102	5.2	2.20	0.42	1.9	520	4	1.10
FY56ED520BC1		123	5.2	1.40	0.45	2.3	720	4	1.40

Technical Specification	
Shaft Diameter	8mm
Step Angle Accuracy	±5% (Full Step, No Load)
Resistance Accuracy	± 10% (20°C)
Inductance Accuracy	±20% (1KHz)
Temperature Rise	80°C Max. (rated current, 2 phase on)
Ambient Temperature	-20°C~+50°C
Insulation Resistance	100MΩ Min. 500VDC
Dielectric Strength	1Min. 500VAC
Shaft Radial Play	0.02Max. 450g Load
Shaft Axial Play	0.08Max. 450g Load
Radial Max. Load	75N
Axial Max. Load	15N
Warranty Period	12 months
Certificate	CE, ROHs, FCC

Motor & Encoder Wiring Diagram

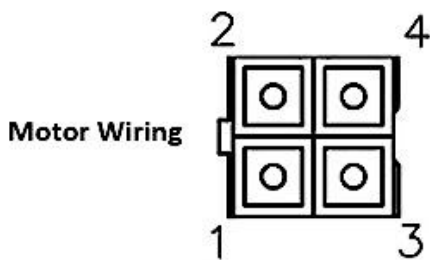

Motor End	Color	Function
1	Blue	B-
2	Red	B+
3	Green	A-
4	Black	A+

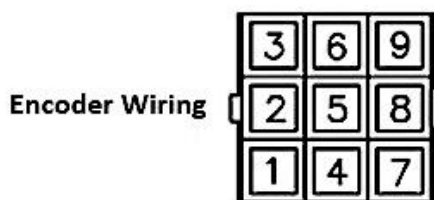

Encoder	Color	Function
1	Blue	EA+
2	—	—
3	Blue/White	EA+
4	Orange	EB+
5	—	—
6	Orange/White	EB-
7	Red	VCC
8	Black	GND
Encoder	Shield	

Speed-Torque Curve Diagram

